

ChIP analysed by q-PCR

Bernadett Papp

(PhD student

EMBL

Heidelberg, Germany)

ChIP I.

studying interactions between endogenous proteins and their native chromatin target site in vivo

1. Formaldehyde crosslink

- Live cells treated with formaldehyde to generate reversible chemical crosslinks between proteins / proteins and DNA located close proximity (2A).
 - ! crosslinking time (over- and undercrosslinking)
 - ! epitope masking, sonication problems

2. Sonication

- Crosslinked cells sonicated to shear the chromatin into uniformly sized pieces of DNA with well-defined lengths.
 - ! optimal fragment length
 - ! Reproducibility

3. Immunoprecipitation

- Fragmented chromatin is subjected to immunoprecipitation with an antibody against the protein of interest under highly stringent conditions.
 - ! antibody quality (affinity purified if possible)
 - ! optimization of the antibody/chromatin ratio to achieve max IP efficiency
 - ! preimmunserum

ChIP II.

4. Reversion of the crosslink

- Several stringent washes reduce the background and the product of the IP is de-crosslinked by proteinaseK and heat treatment.

5. Extraction of the immunoprecipitated DNA

! purity (affecting the qRT-PCR)

! contamination (DNA)

! Loss of DNA (DNase)

6. q-PCR !!!!!!!

- If a protein under investigation is associated with a specific genomic region in vivo, DNA fragments from this region should be enriched in the immunoprecipitate compared to other portions of the genome.

= The presence and the quantity of relevant genomic regions in the IP are determined

- It is not possible to compare the amounts of proteins within a primer pair from one IP to another using different antibodies since different antisera have different precipitation efficiencies. Comparisons should be made only on the same protein in 2 different genomic regions.

ChIP III.

- The sample values are compared to those obtained from known amounts of input DNA.

(Input is the total of chromatin-DNA used for one IP.)

(Serial dilutions of genomic DNA is used for the standard curve.)

! primer design, quality control of the PCR

! ctrl regions (pos and neg)

! Input material

7. Data analysis and interpretation

- The results can be plotted in diagrams as percentage of the input with the different genomic regions on the X axis.

! Independent experiments from independent chromatins

! Diagram types (% of Input versus fold enrichments over preimmune/ctrl regions)

! Substraction of background, normalization

! Interpretation of the data !!!!

“Negative is negative. Positive? Antibody IPs what is IPs.”

**ChIP studies on a HOX gene regulated by
Polycomb group and trithorax group proteins**

INITIATION

localized

gap
proteins

pair-rule
proteins

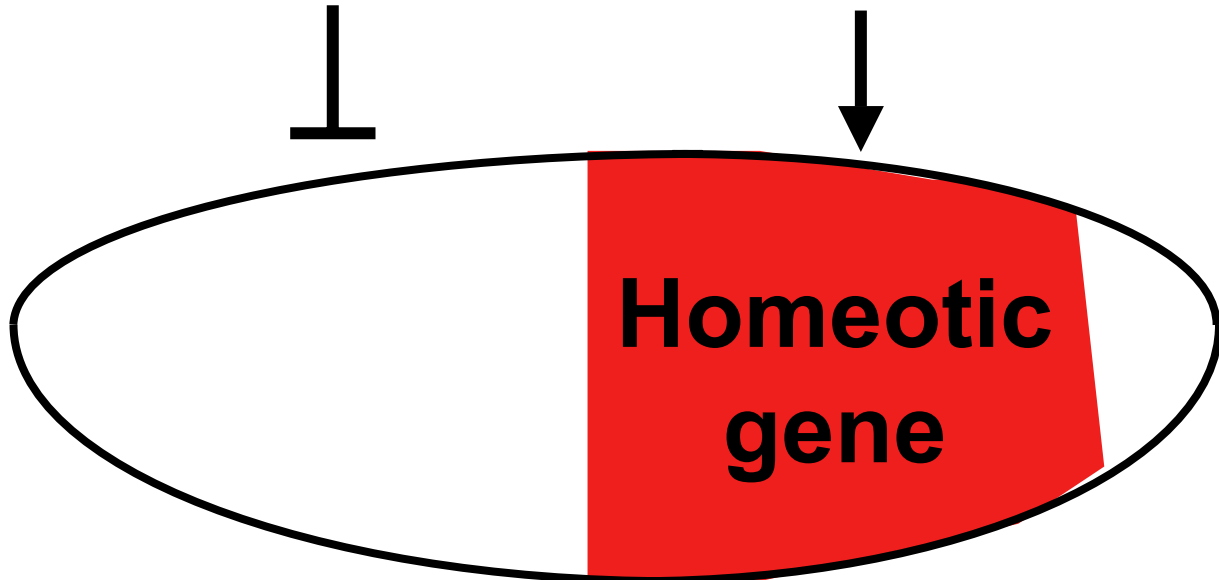

ubiquitous

Polycomb
group proteins

trithorax
group proteins

MAINTENANCE

Control of HOX gene expression by Polycomb group (PcG) and trithorax group (trxG) regulators

wt

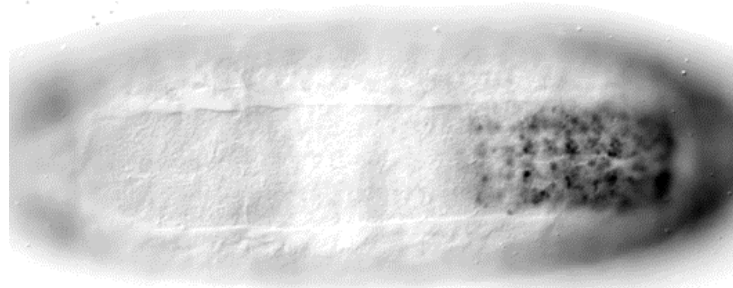

Scm⁻
(PcG)

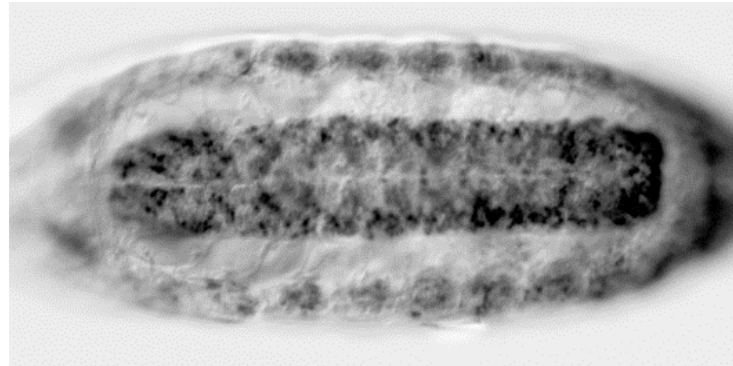

trx⁻
(trxG)

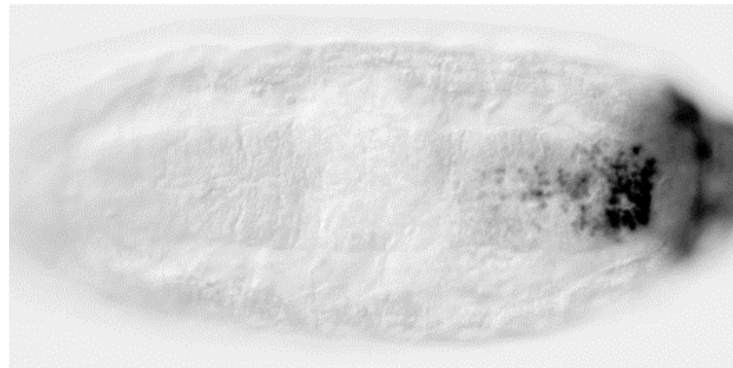

α -Abd-B

Polycomb response elements (**PREs**)

- silencers
- anchor sites for Polycomb group proteins

Polycomb group (PcG)

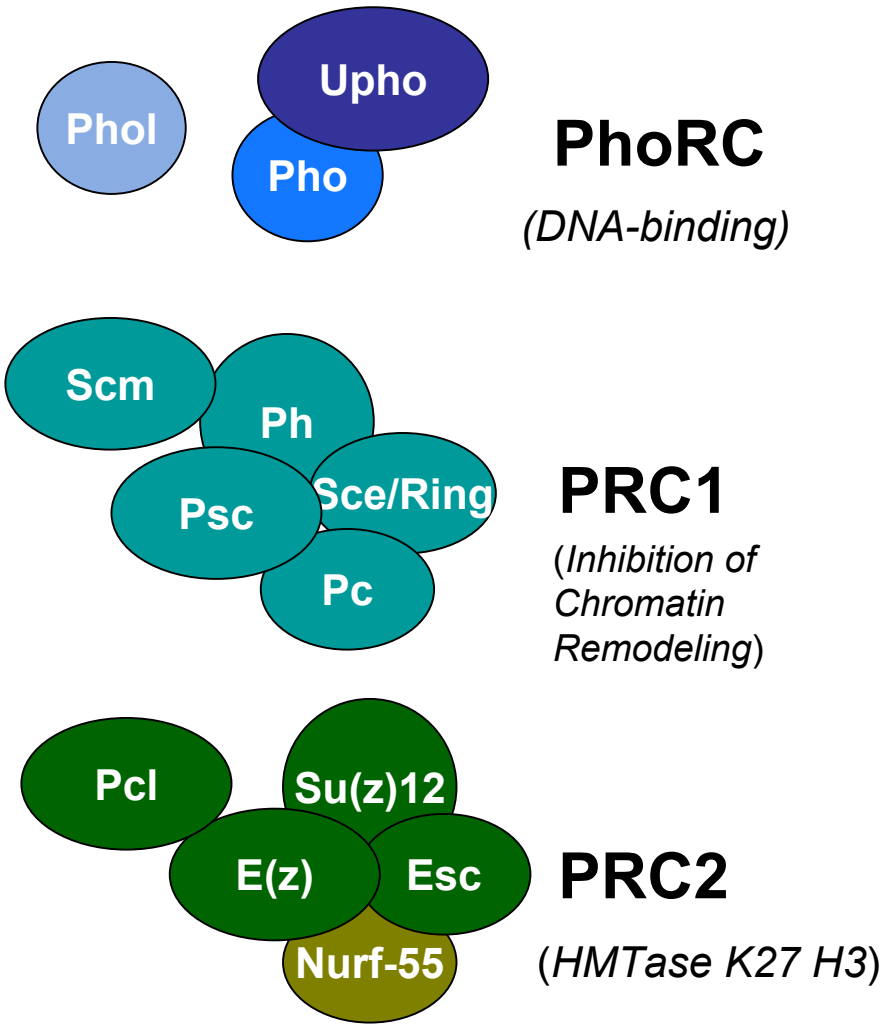

OFF state

trithorax group (trxG)

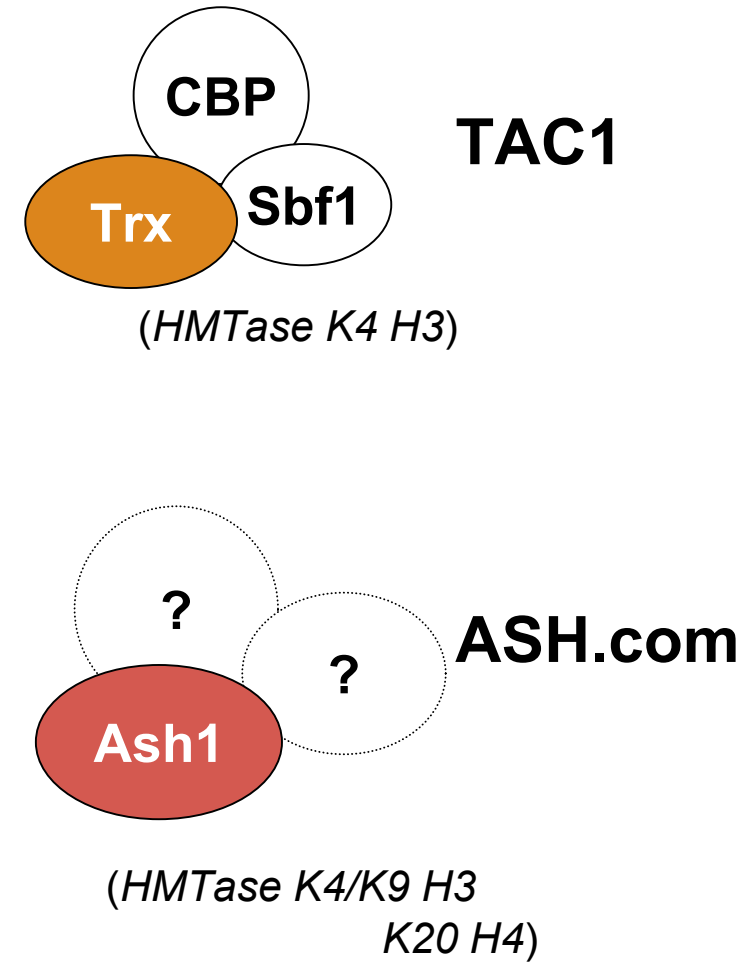

ON state

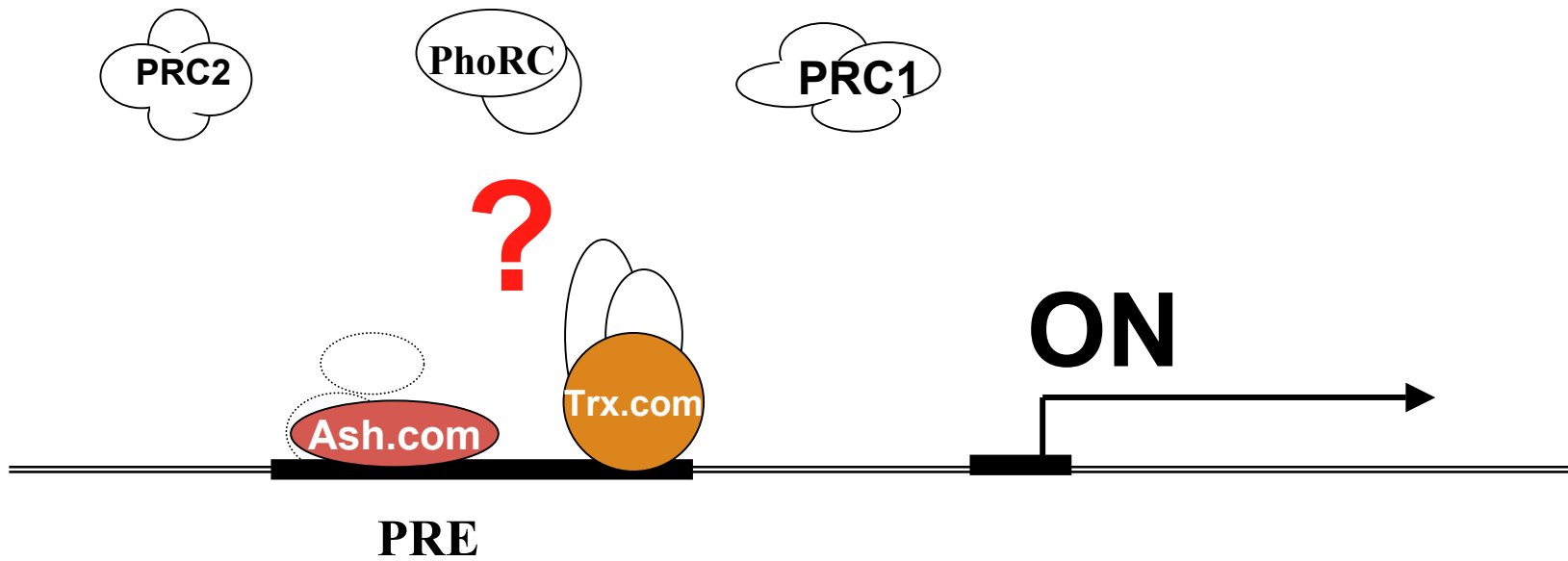
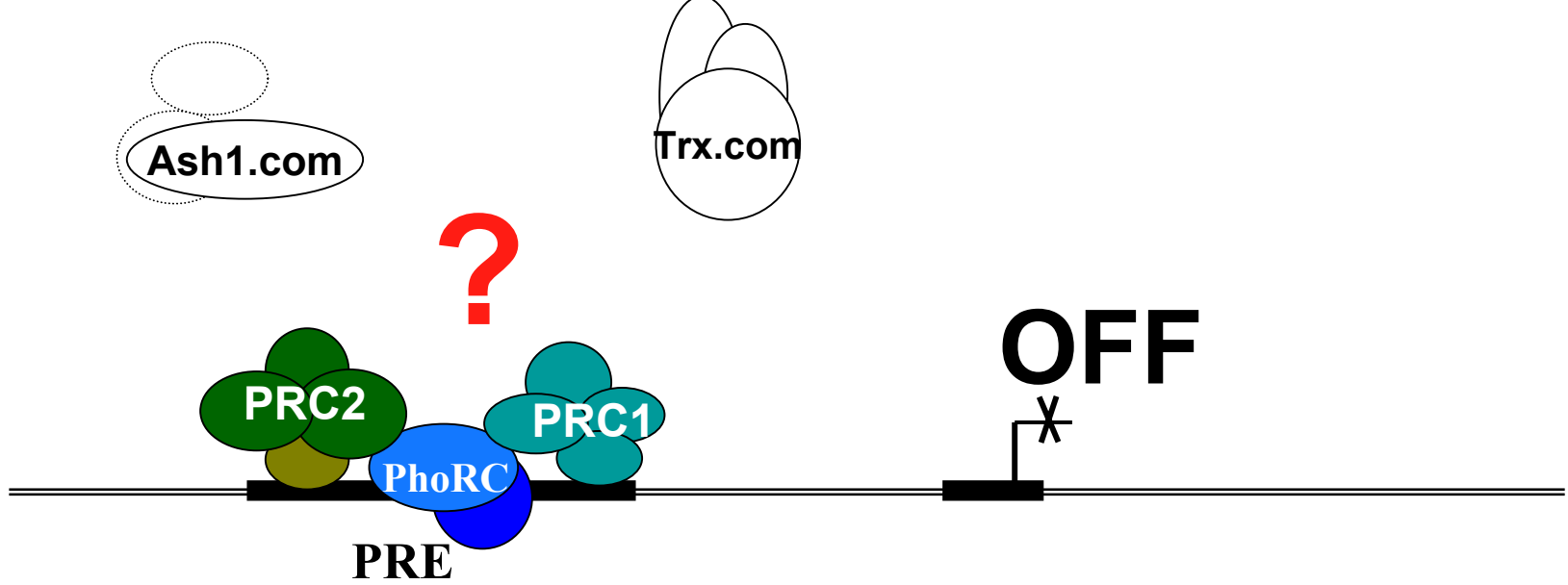

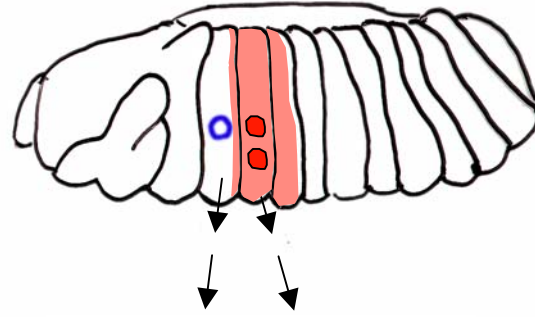

cell divisions

Ubx OFF

wing disc

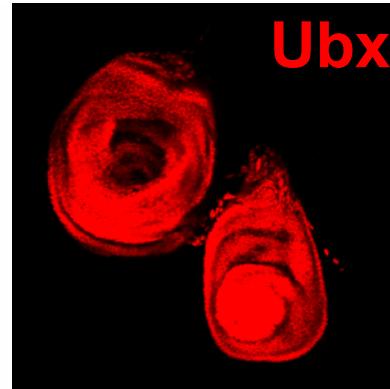
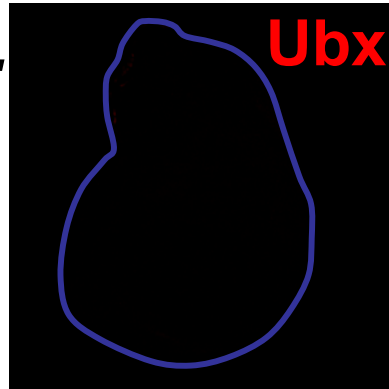

Ubx ON

haltere disc
+
3rd leg disc

X-ChIP

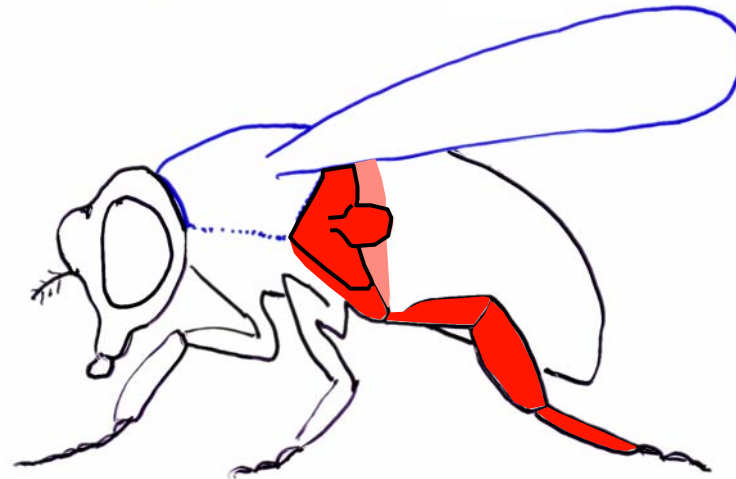

X-ChIP

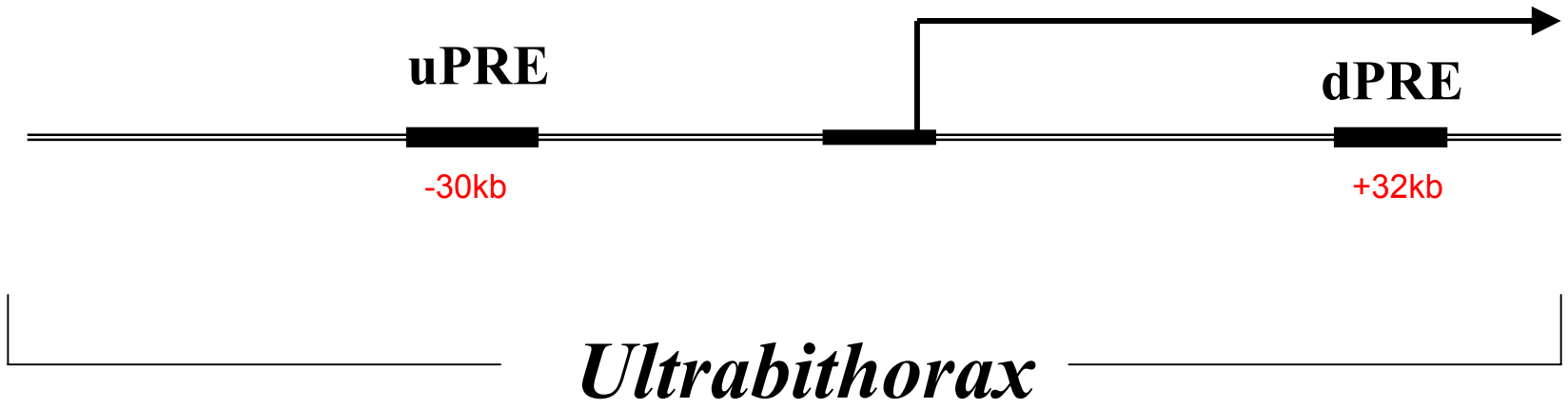

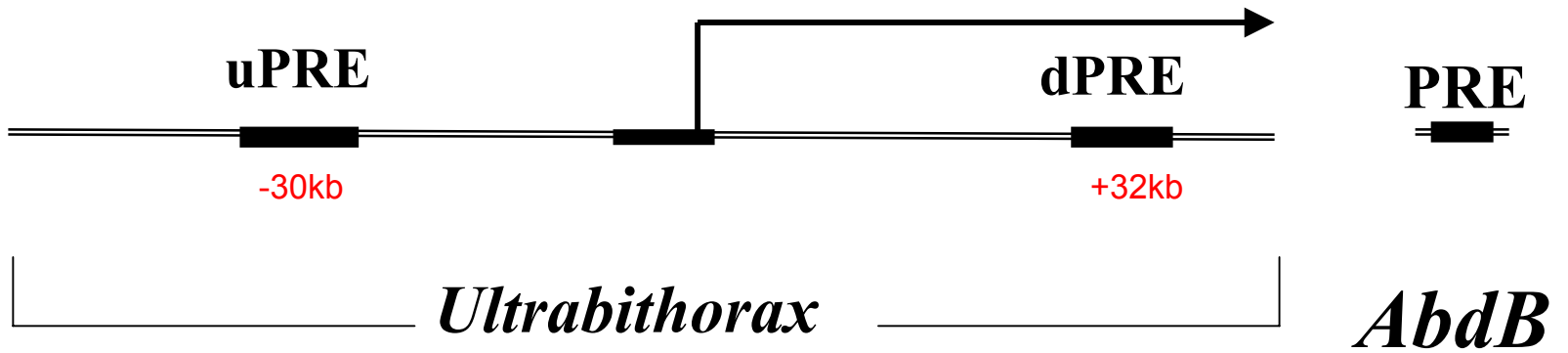

Wing

OFF

OFF

Haltere/3rd leg

ON

OFF

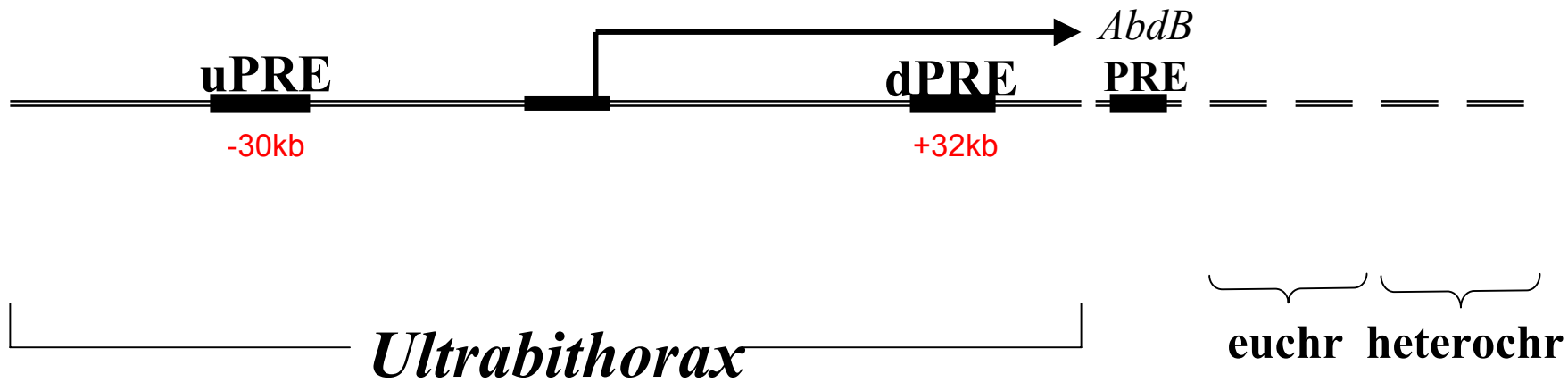

Wing	OFF	OFF	-
Haltere/3rd leg	ON	OFF	-

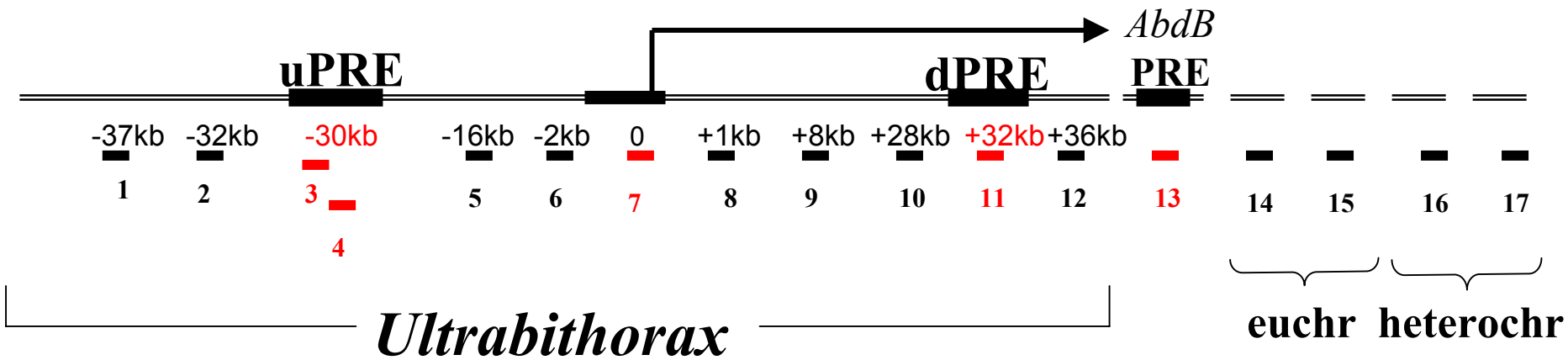

Wing	OFF	OFF	-
Haltere/3rd leg	ON	OFF	-

Polycomb group (PcG)

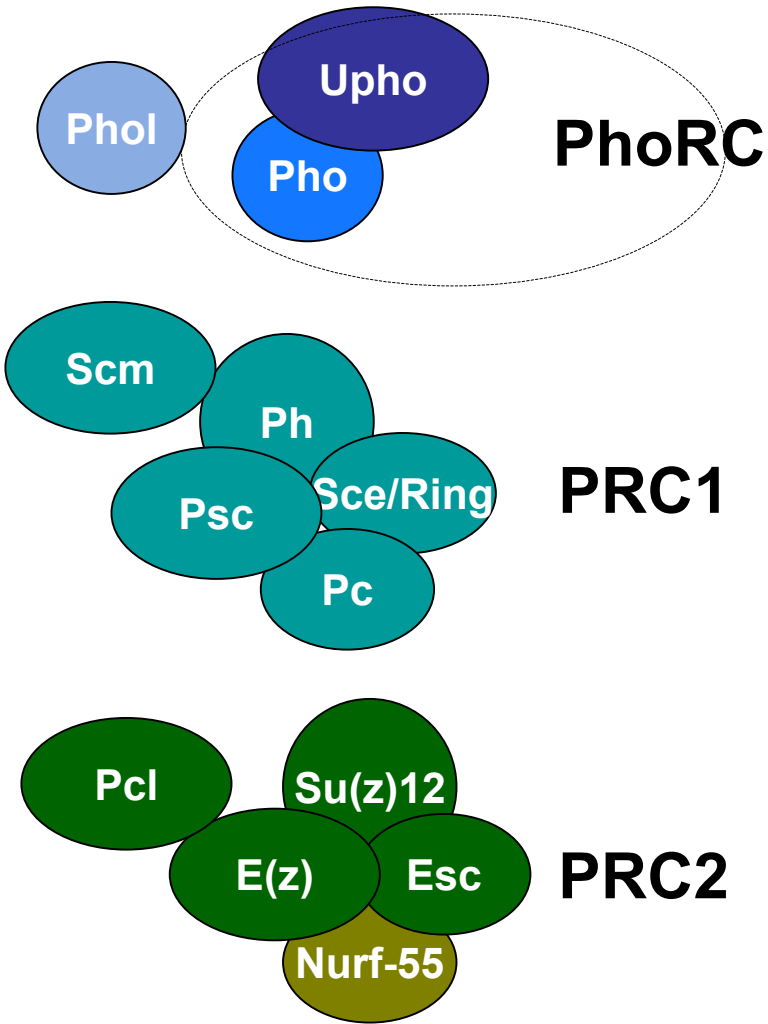

OFF state

trithorax group (trxG)

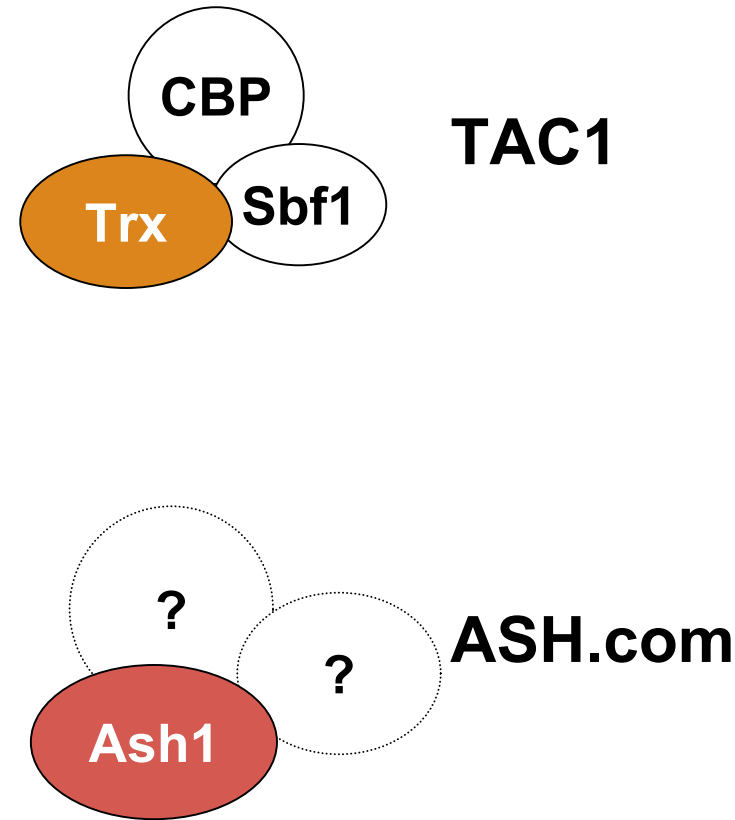

ON state

Pre-Immune

Ubx OFF
 Ubx ON

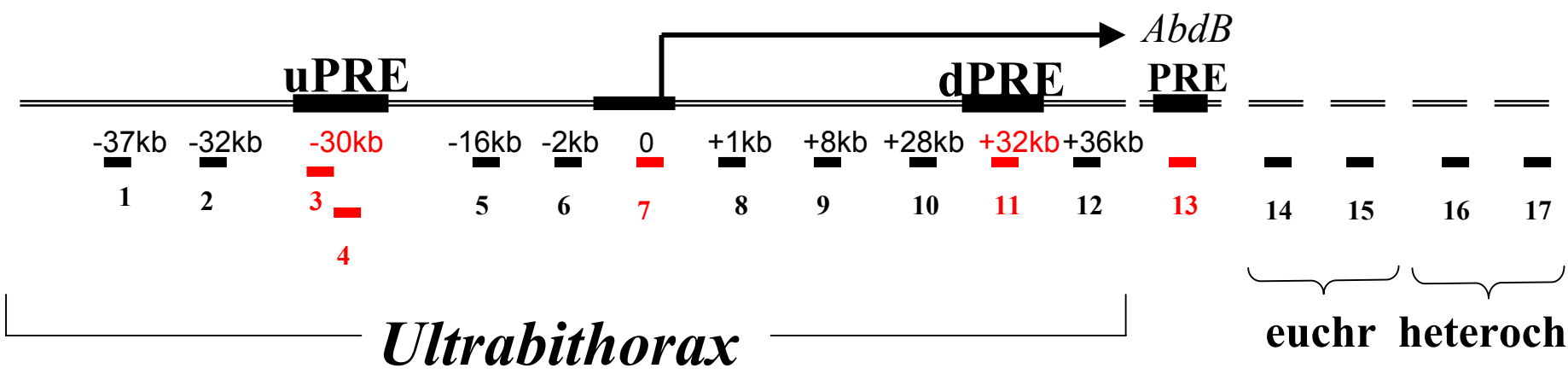
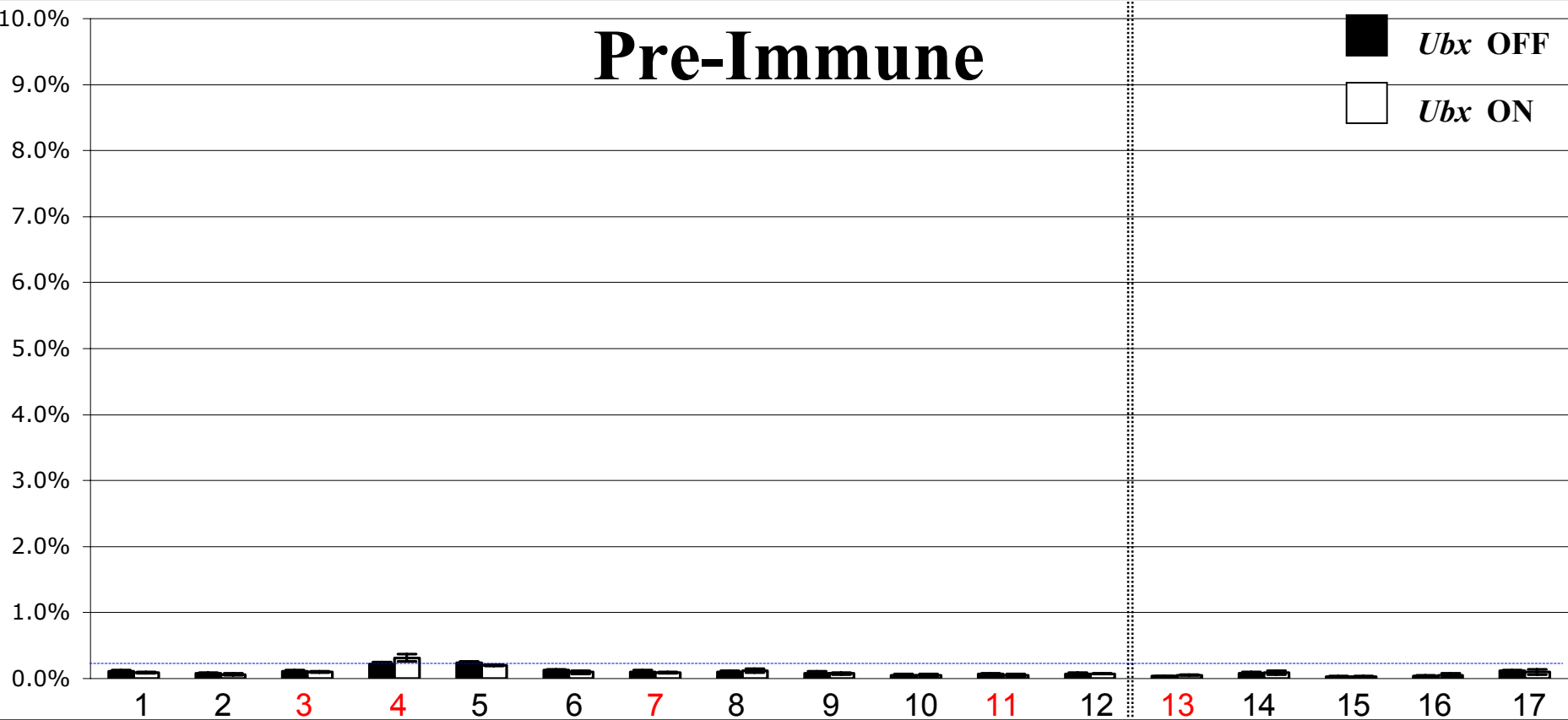

Pho

Ubx OFF
 Ubx ON

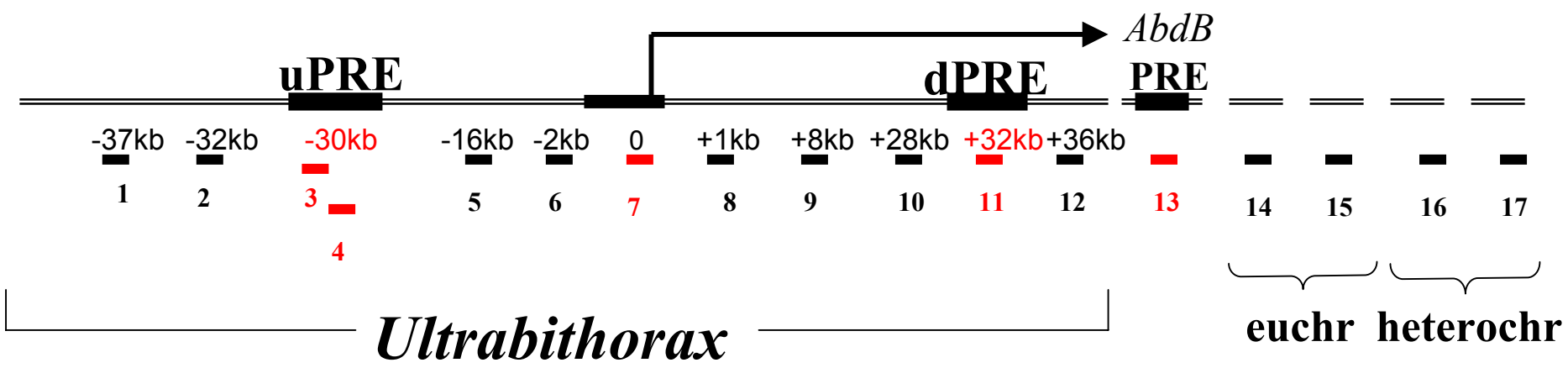
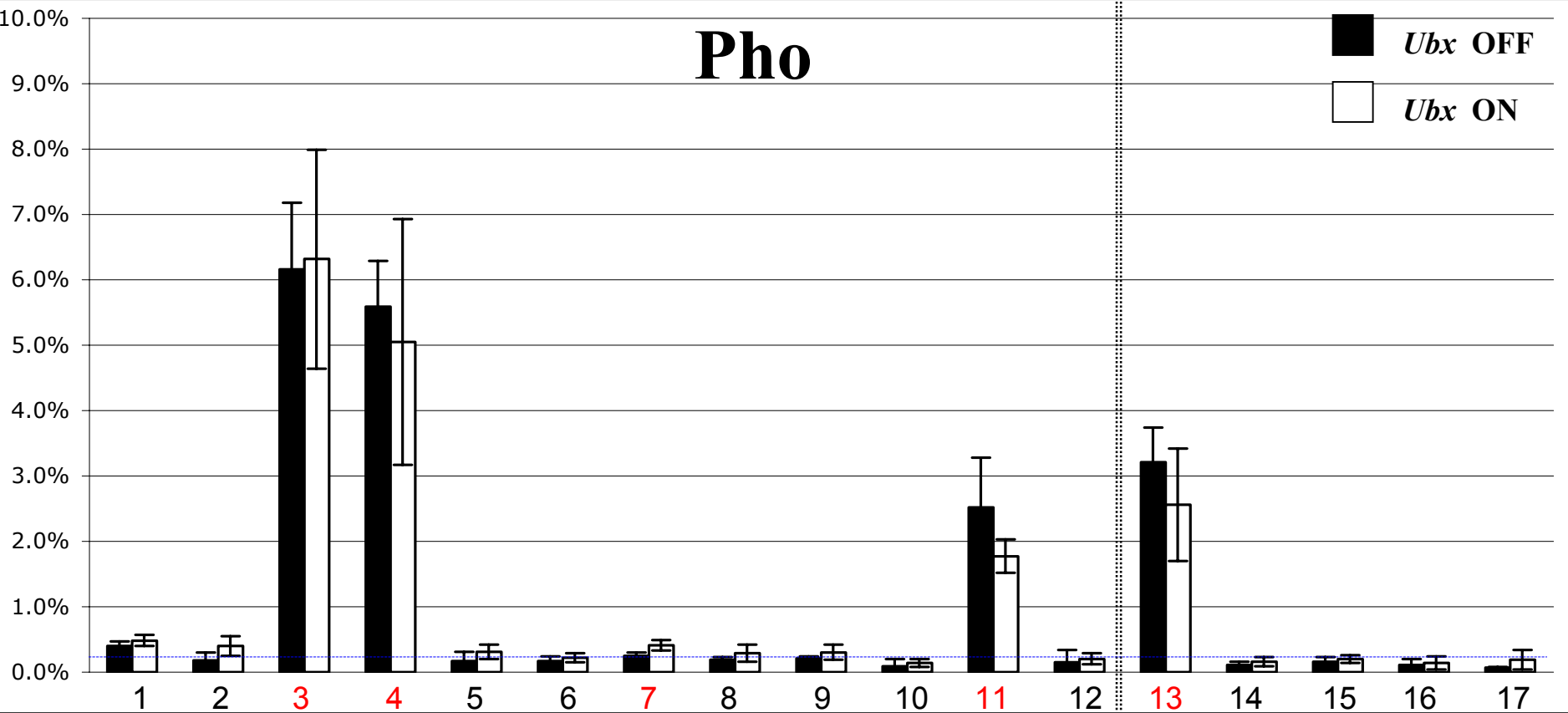

Polycomb group (PcG)

trithorax group (trxG)

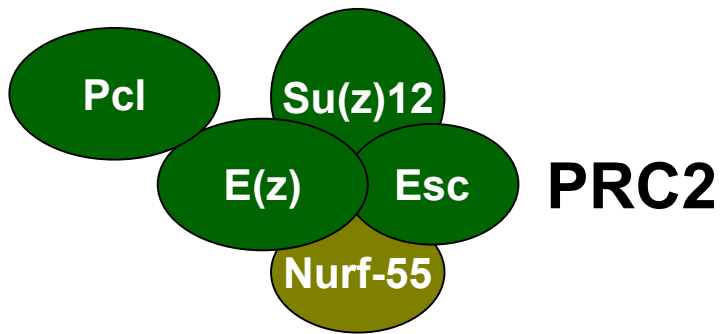
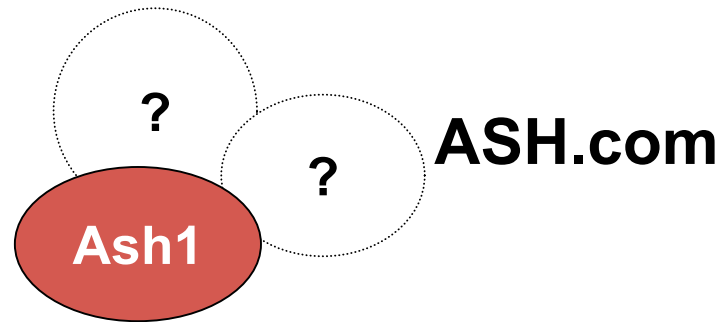
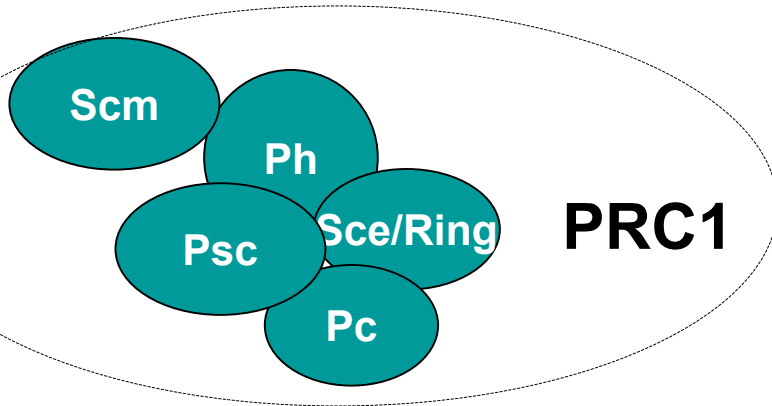
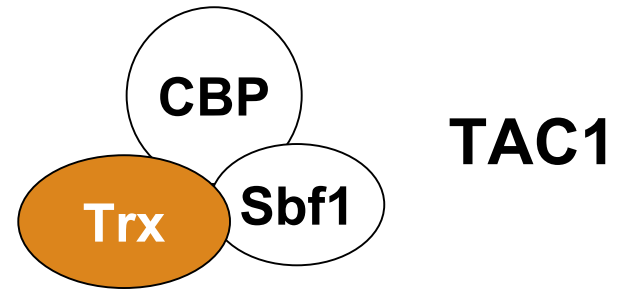
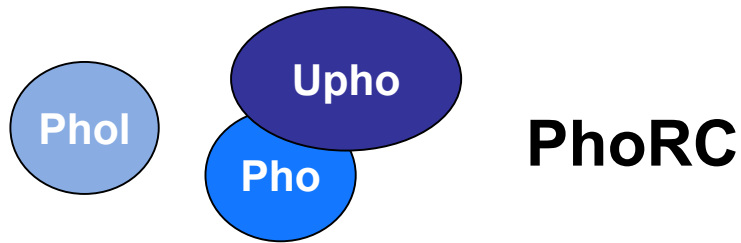

OFF state

ON state

Psc

Ubx OFF
 Ubx ON

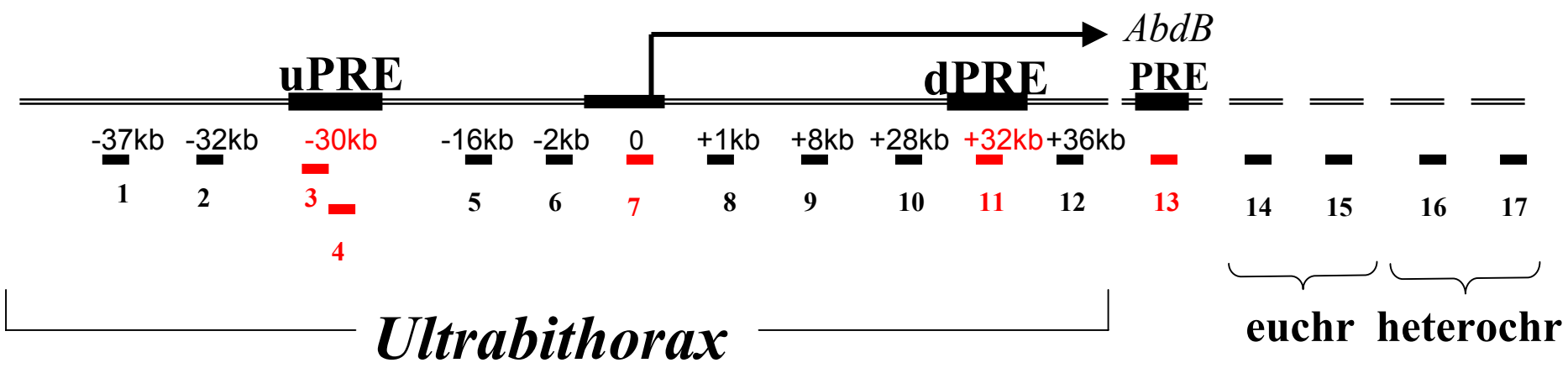
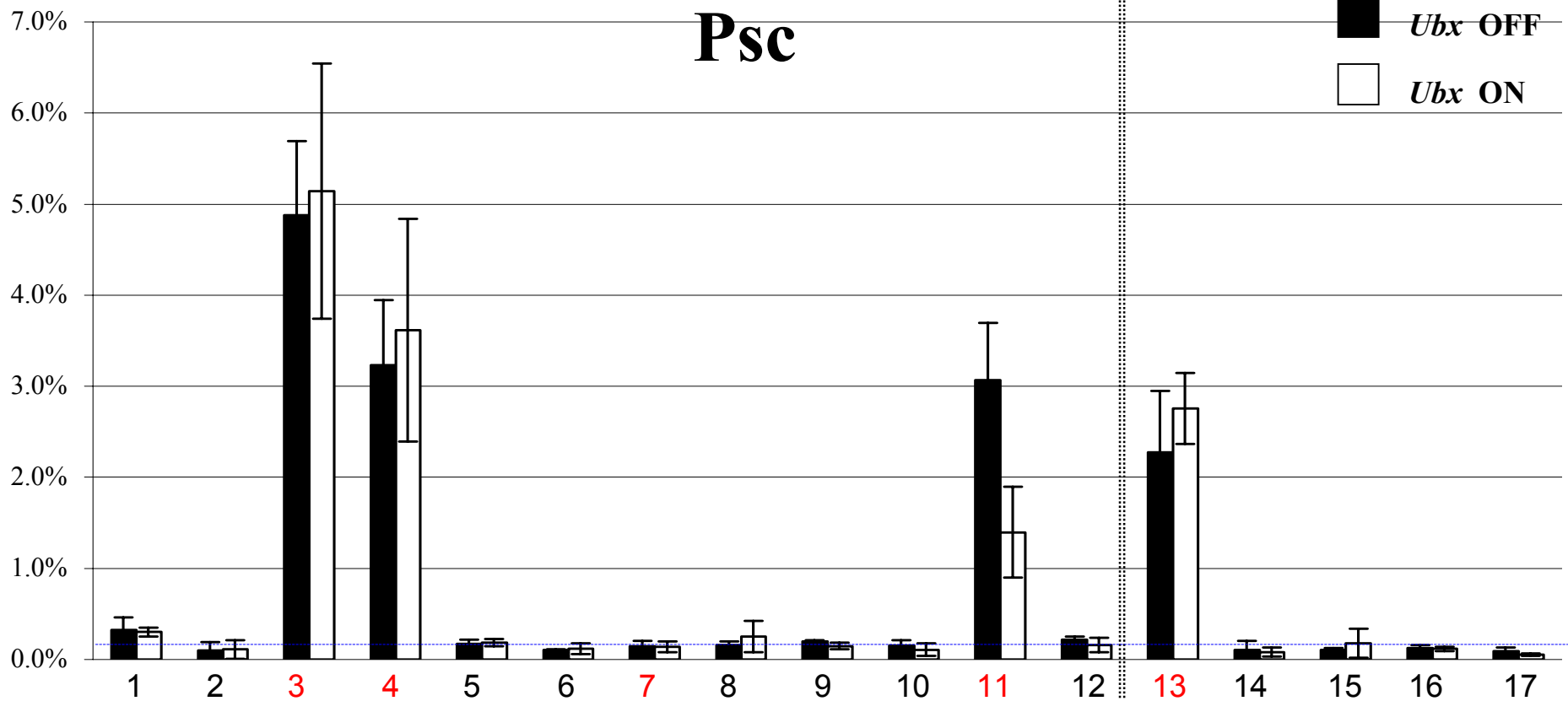

Pc

■ *Ubx* OFF
□ *Ubx* ON

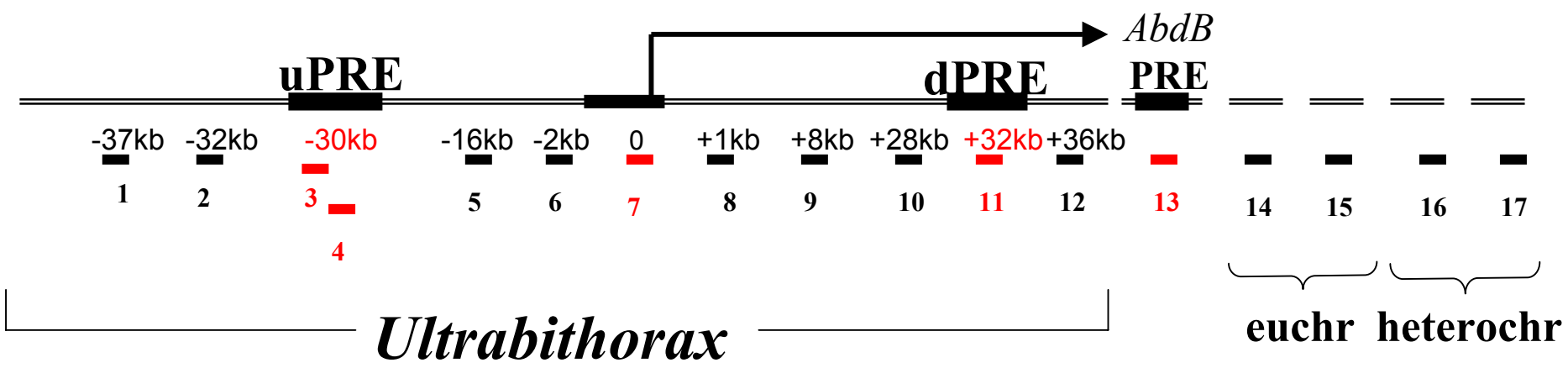
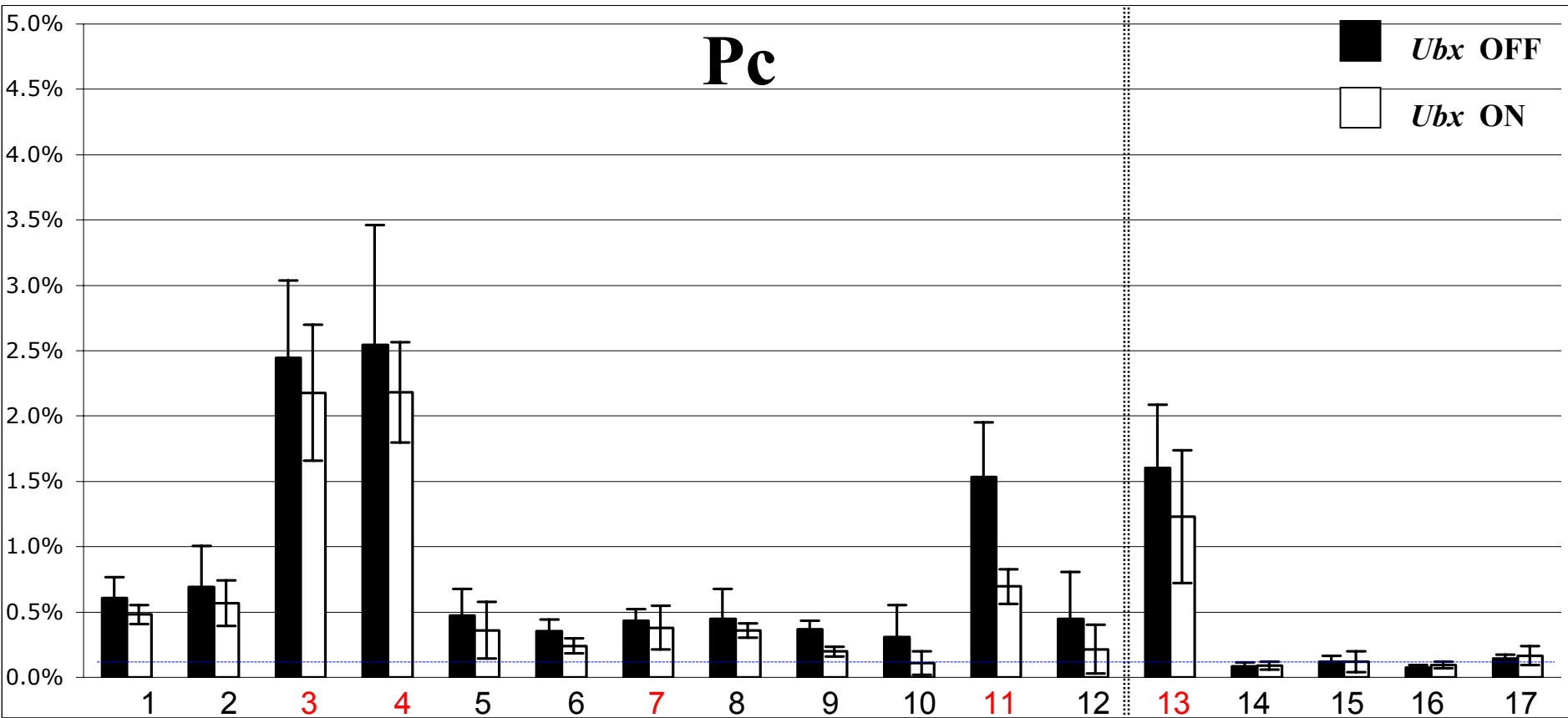

Polycomb group (PcG)

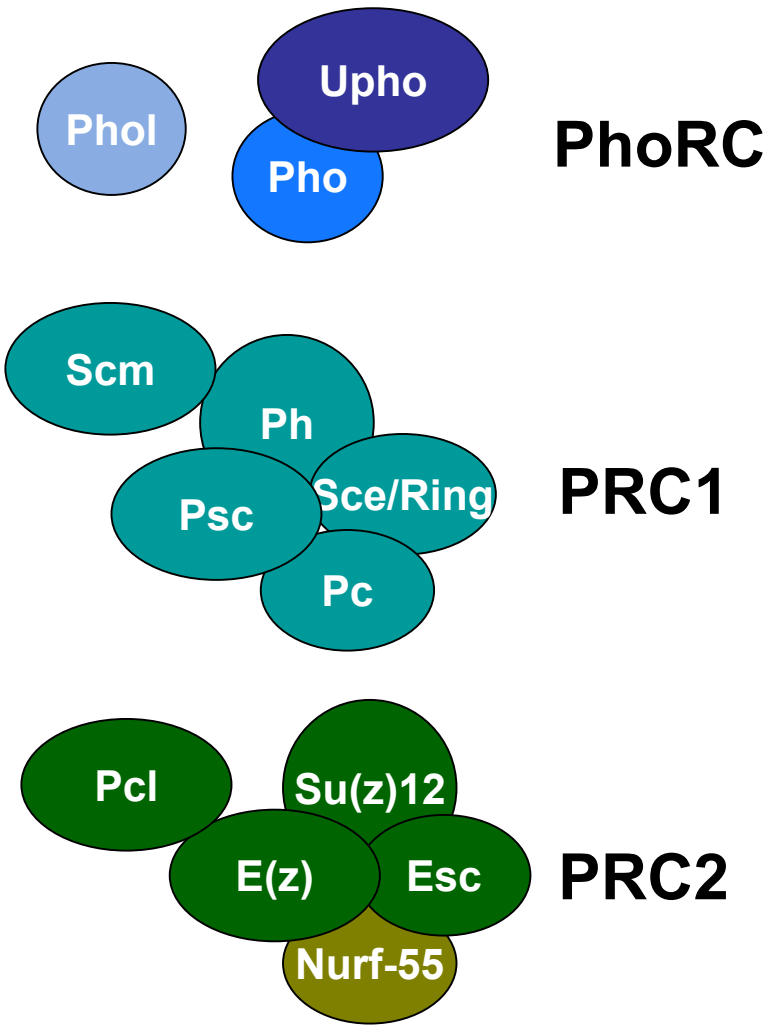

OFF state

trithorax group (trxG)

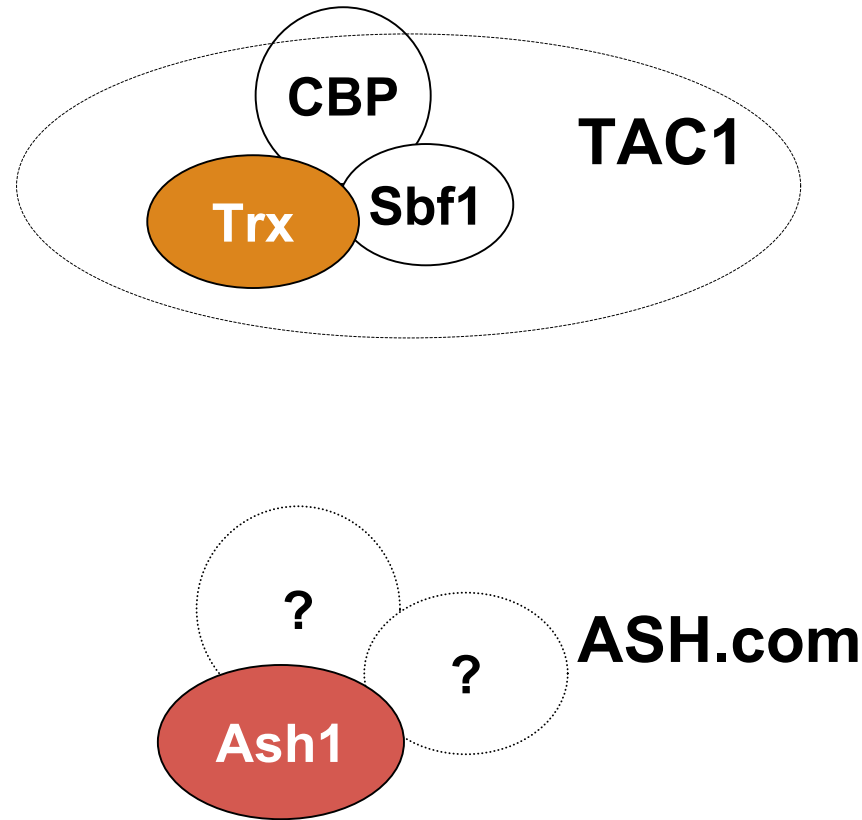

ON state

Trx

Ubx OFF
 Ubx ON

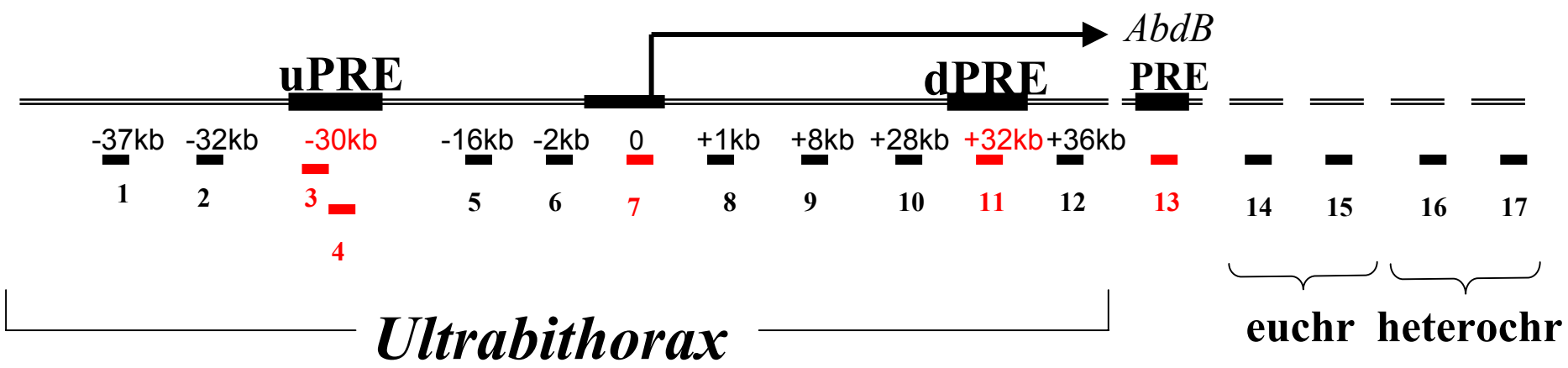
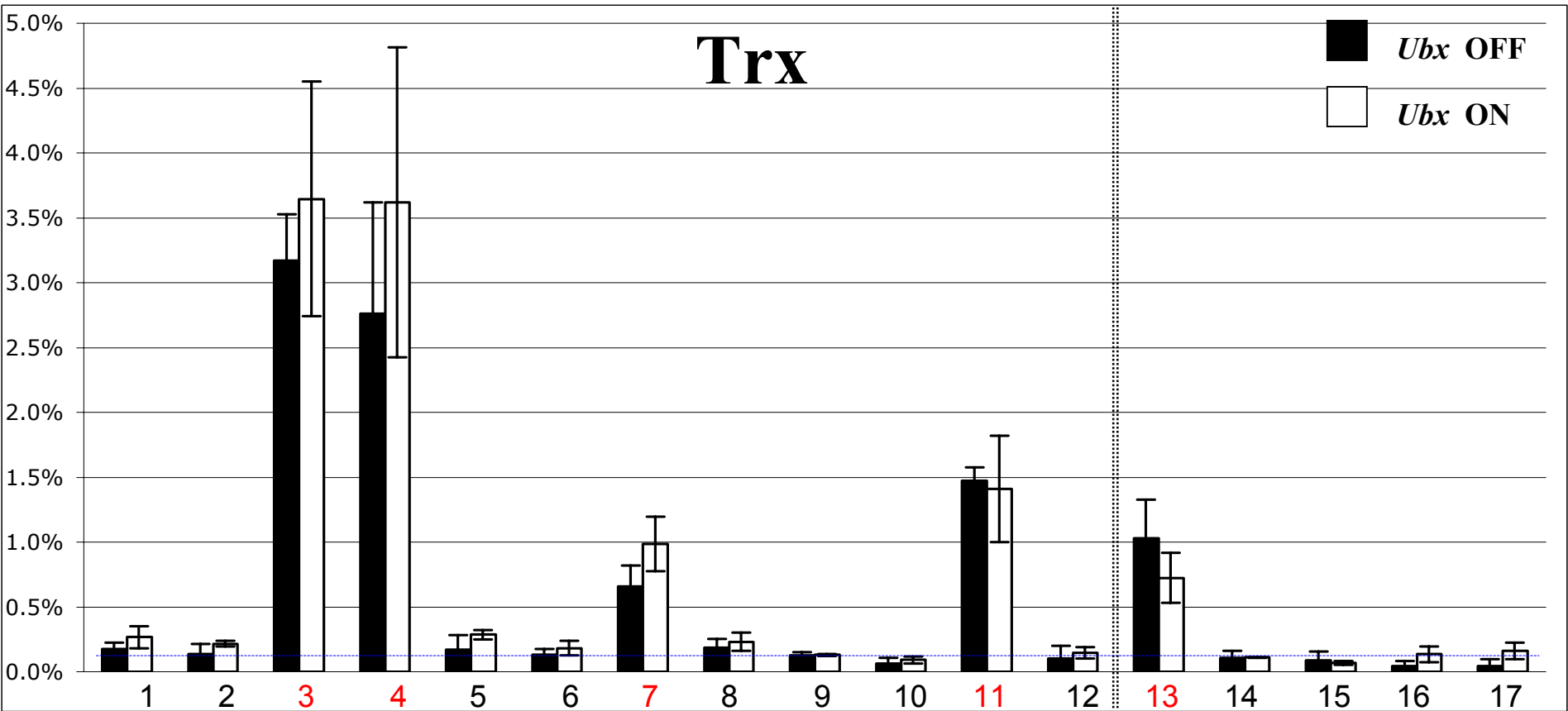

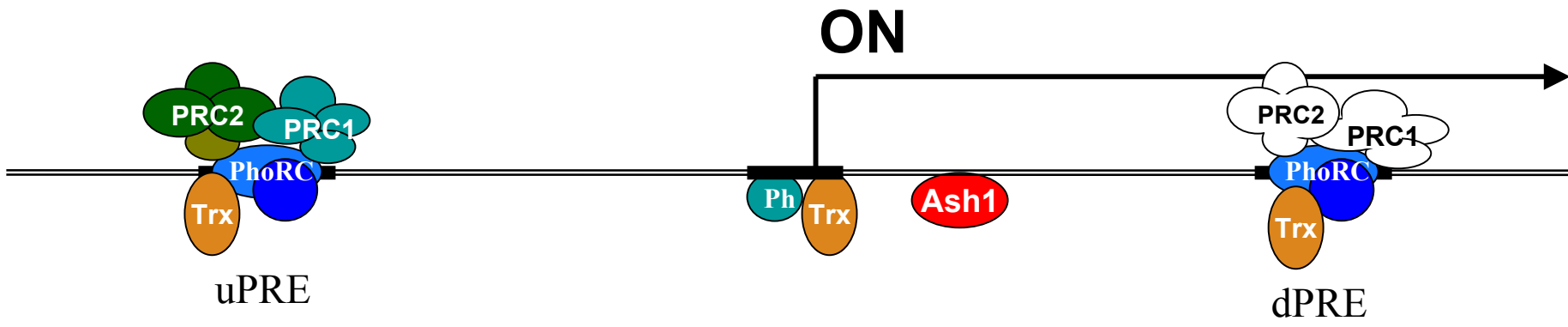
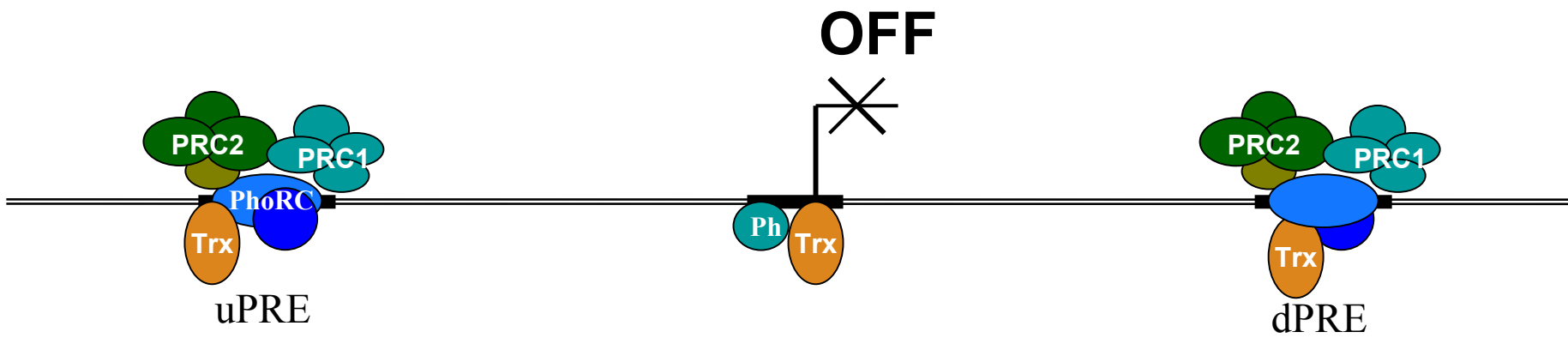

TBP

Ubx OFF
 Ubx ON

* not measured

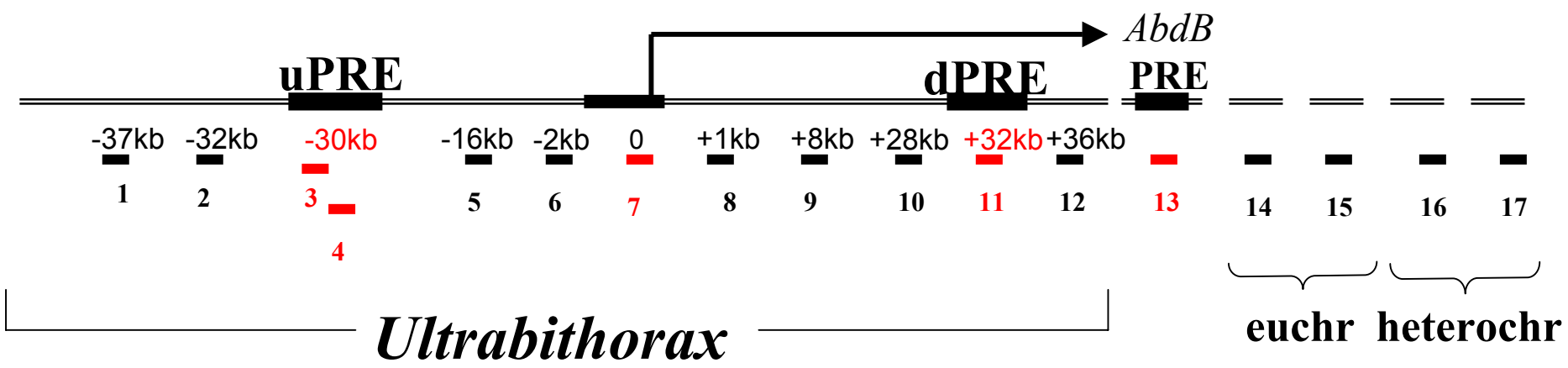
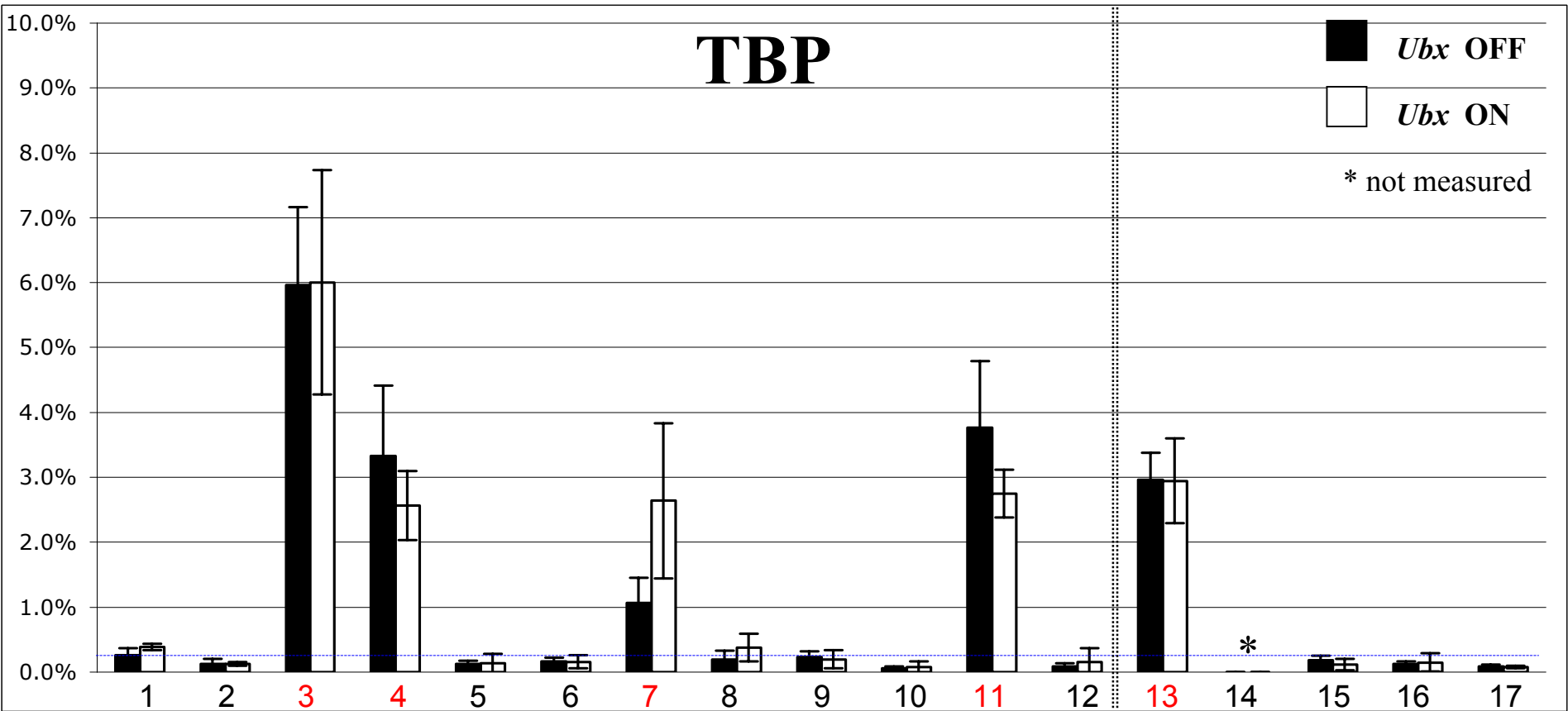

Spt5

Ubx OFF
 Ubx ON

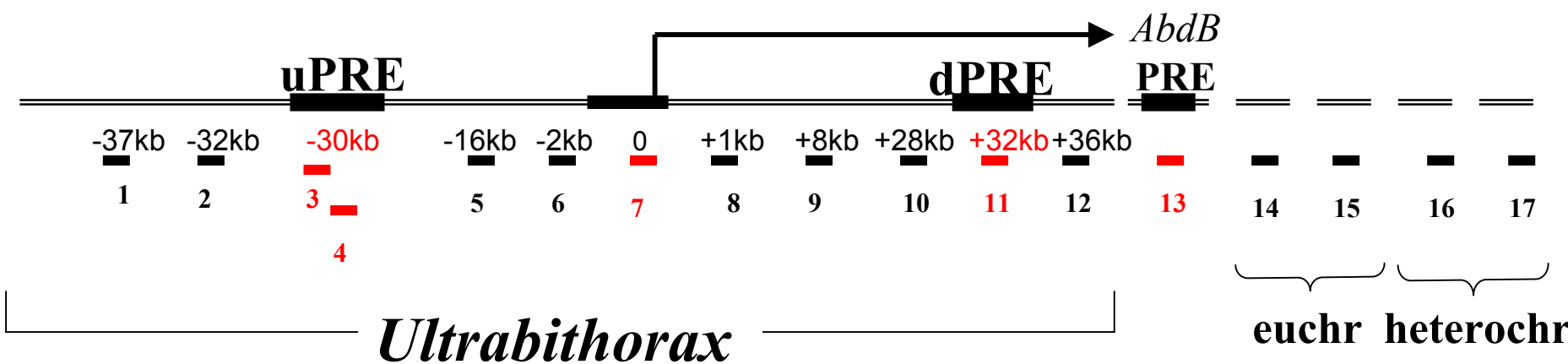
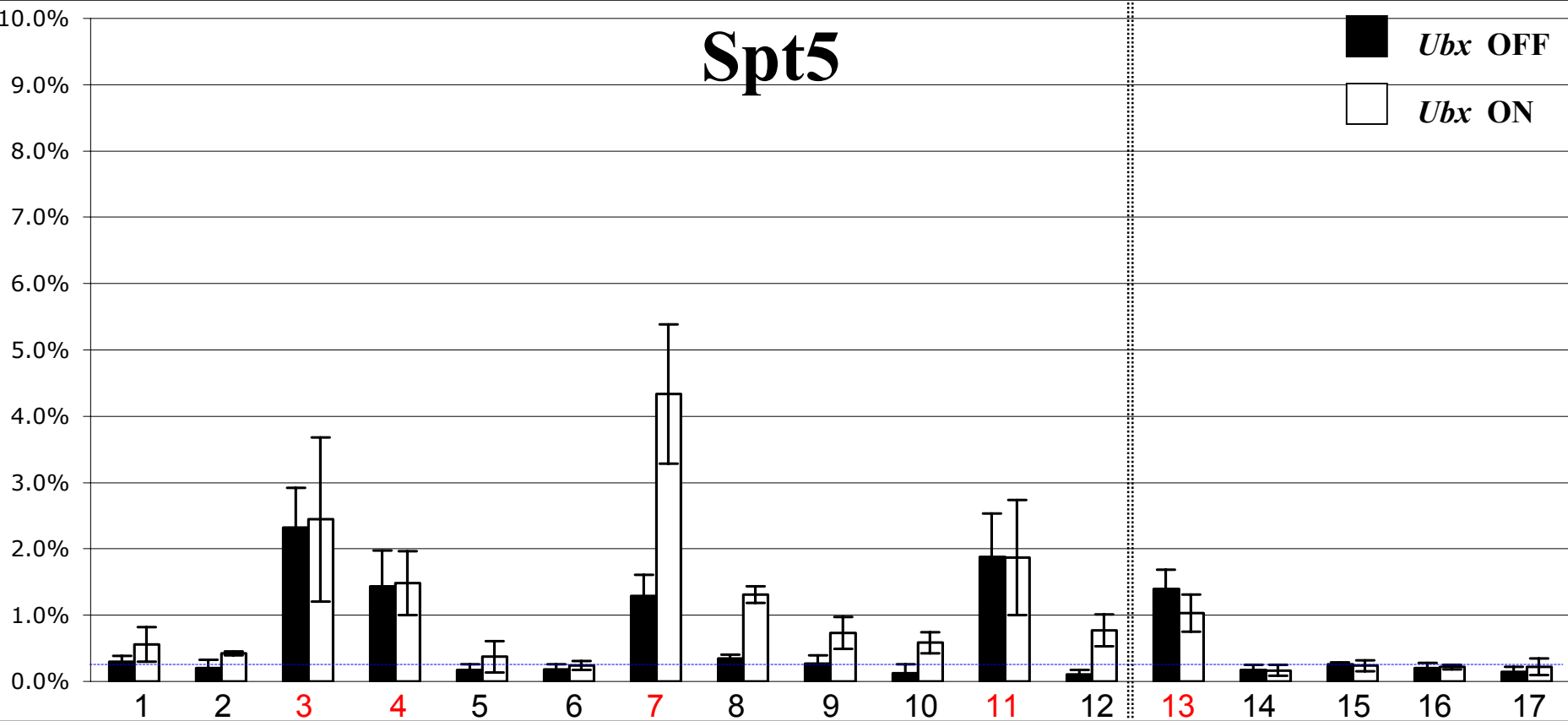

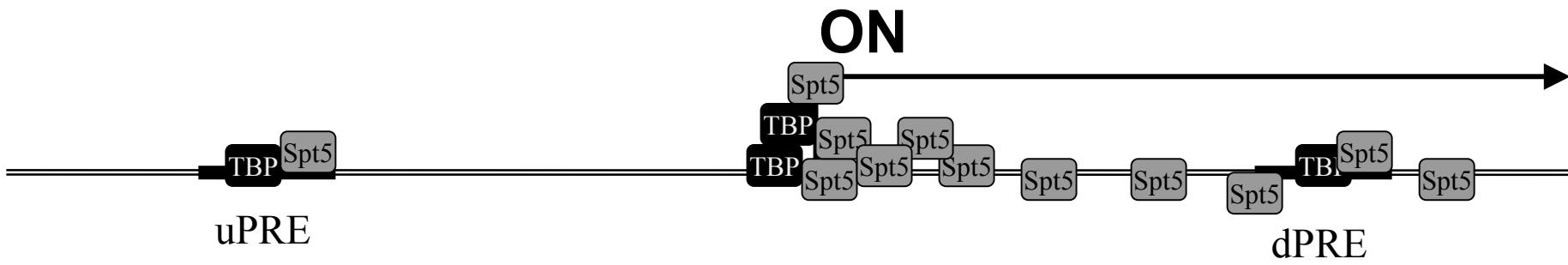
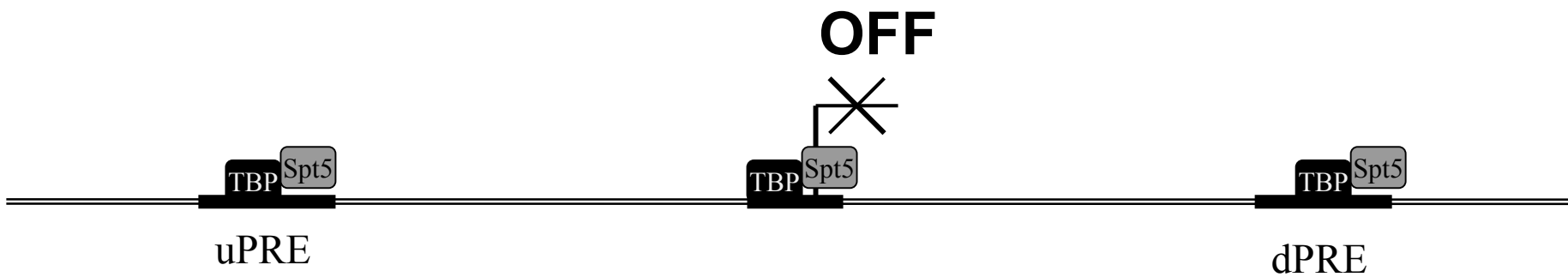

Polycomb group (PcG)

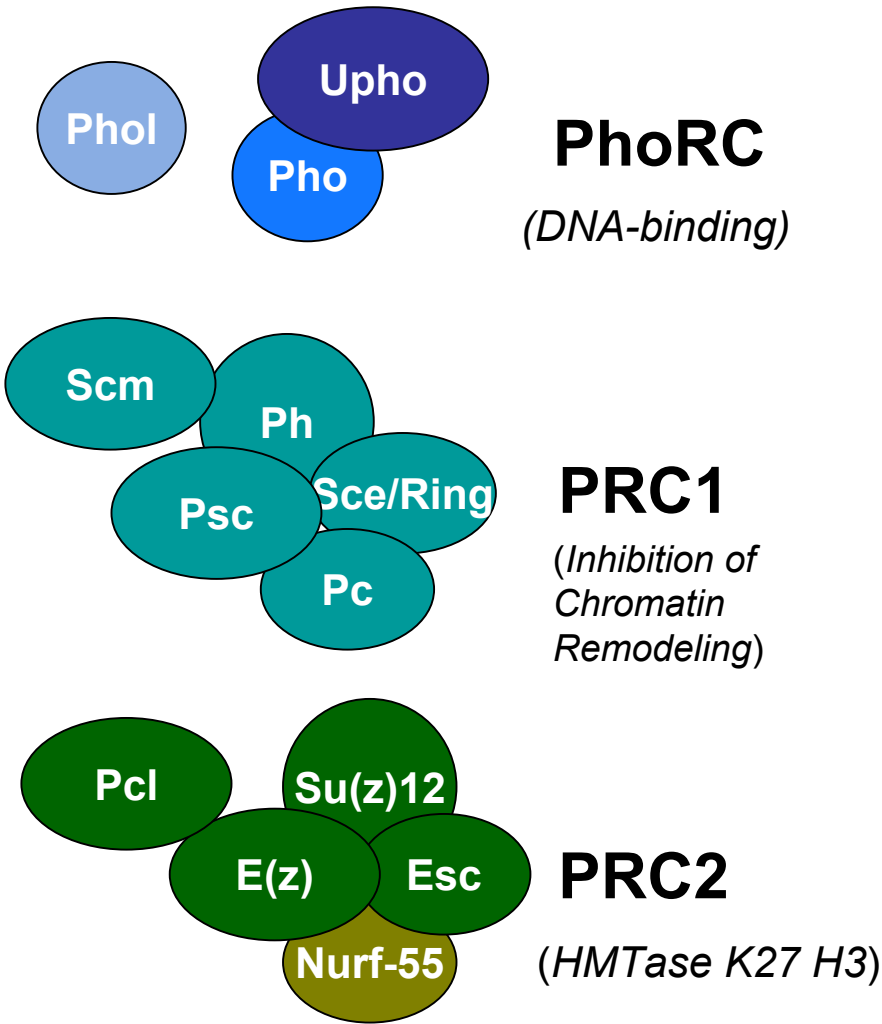

OFF state

trithorax group (trxG)

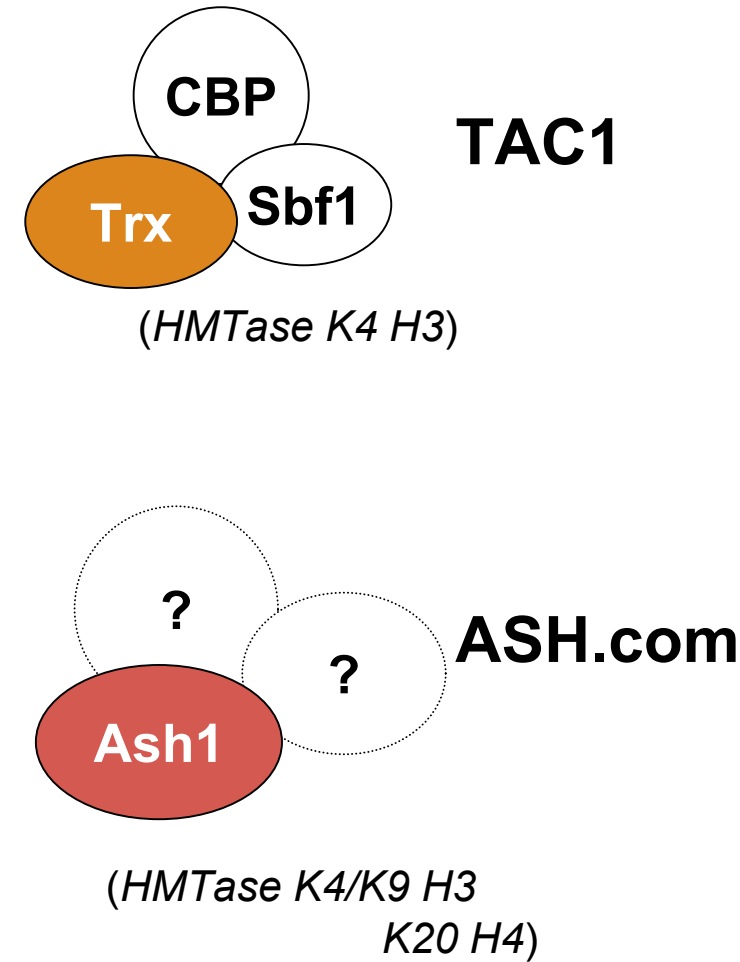

ON state

Histone H4

Ubx OFF
 Ubx ON

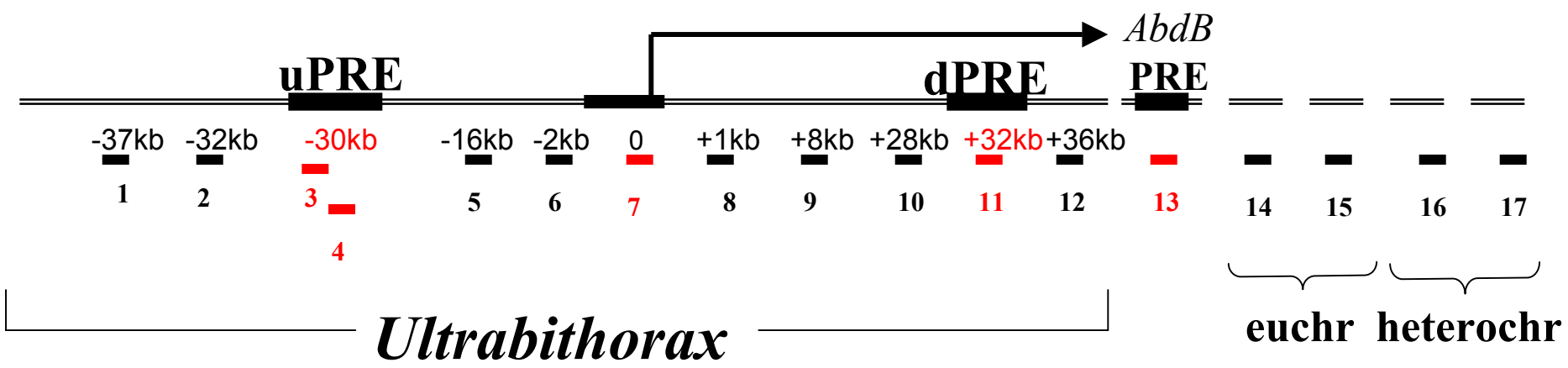
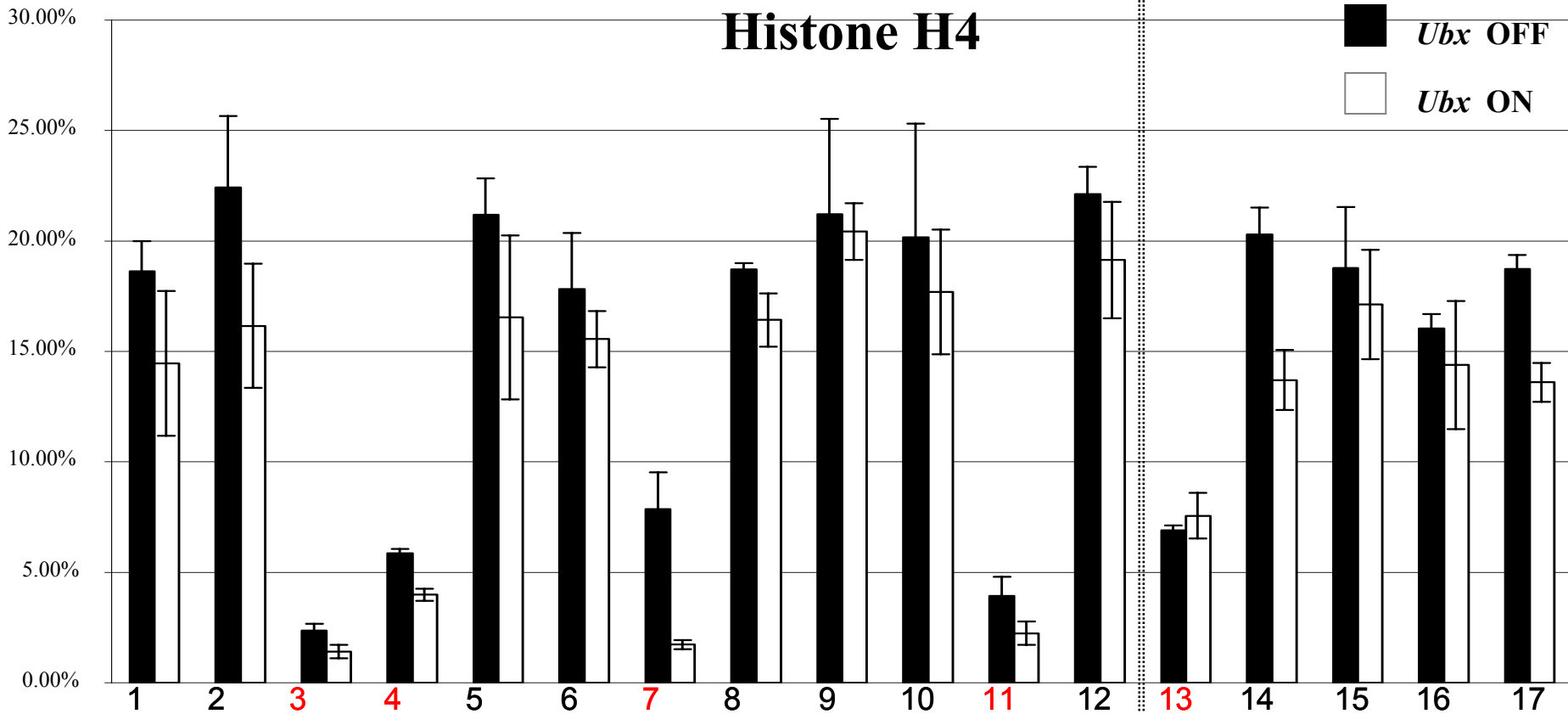

Histone H3

Ubx OFF
 Ubx ON

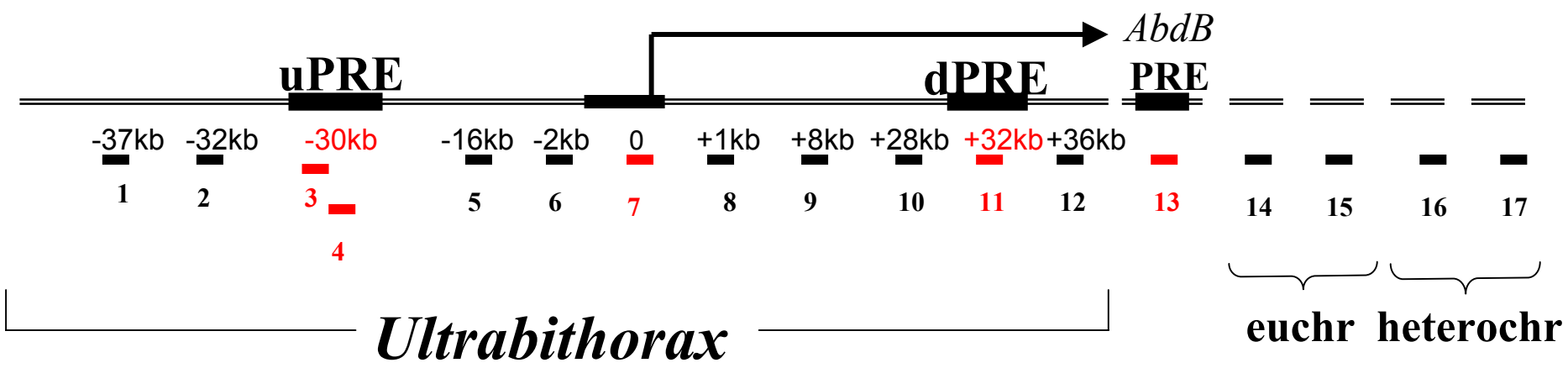
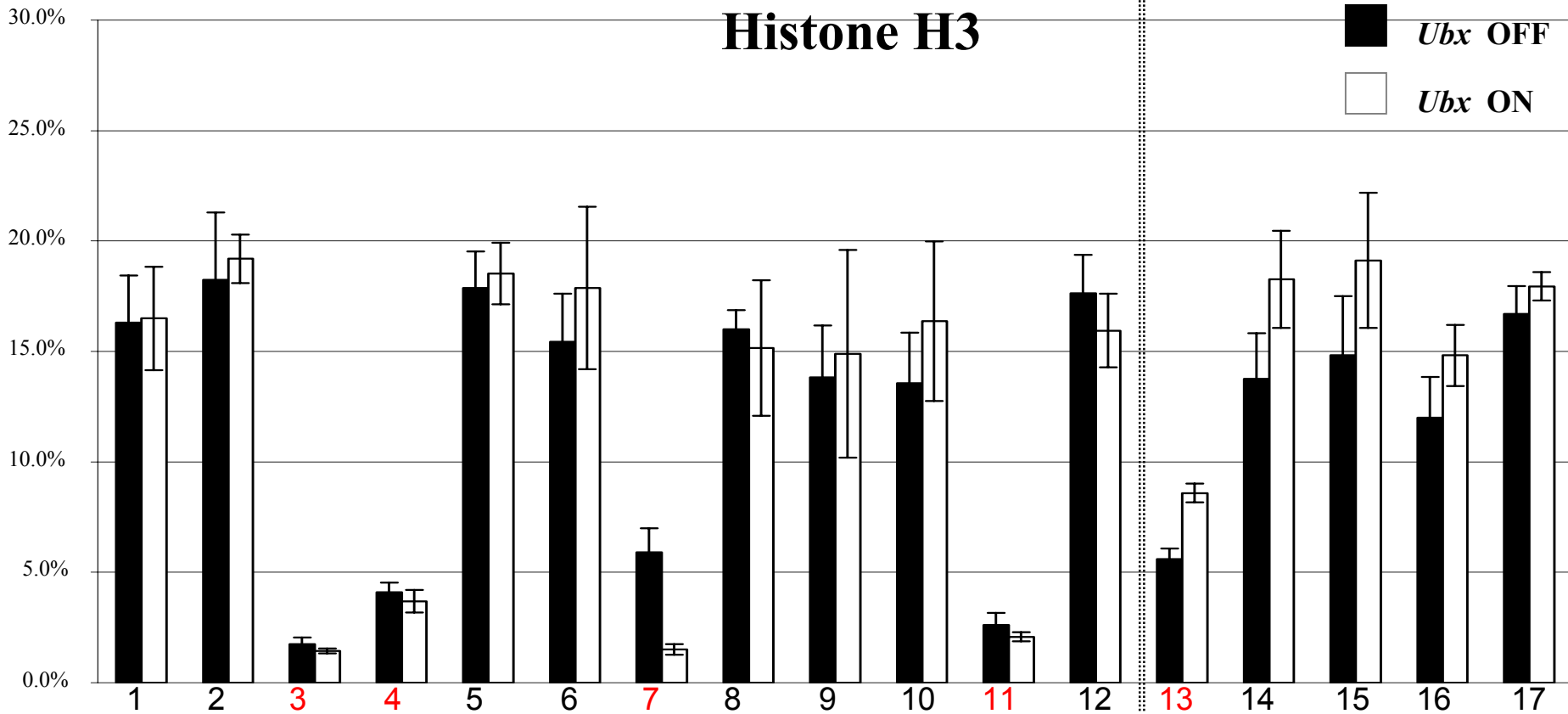

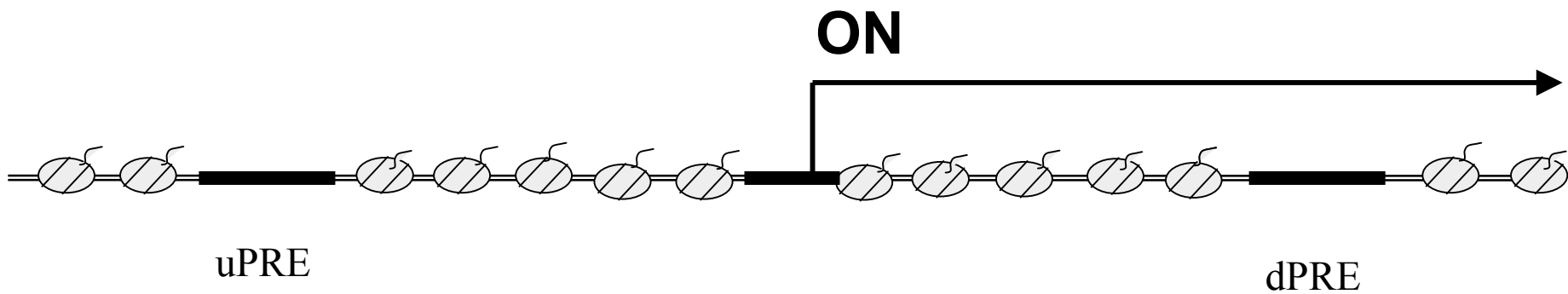
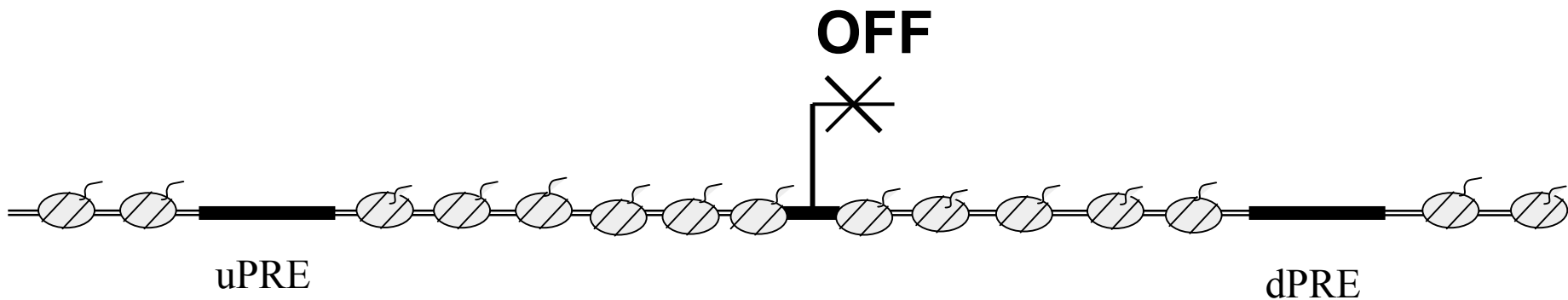

H3K4me3

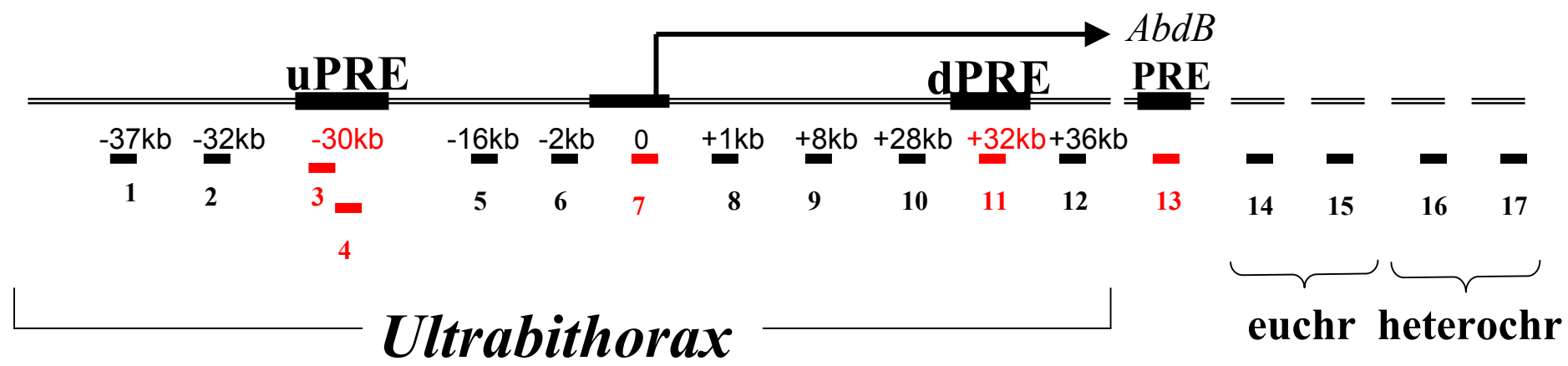
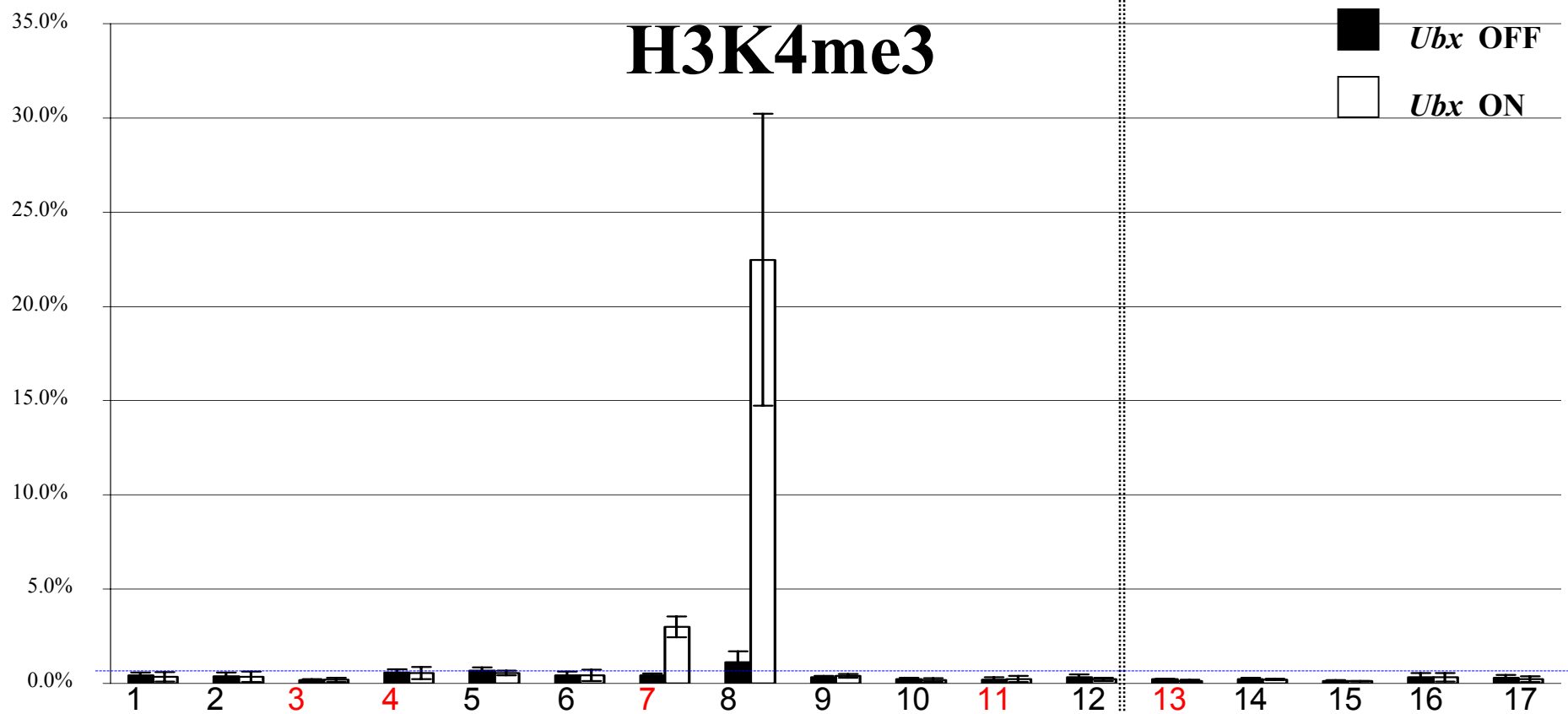

H3K27me3

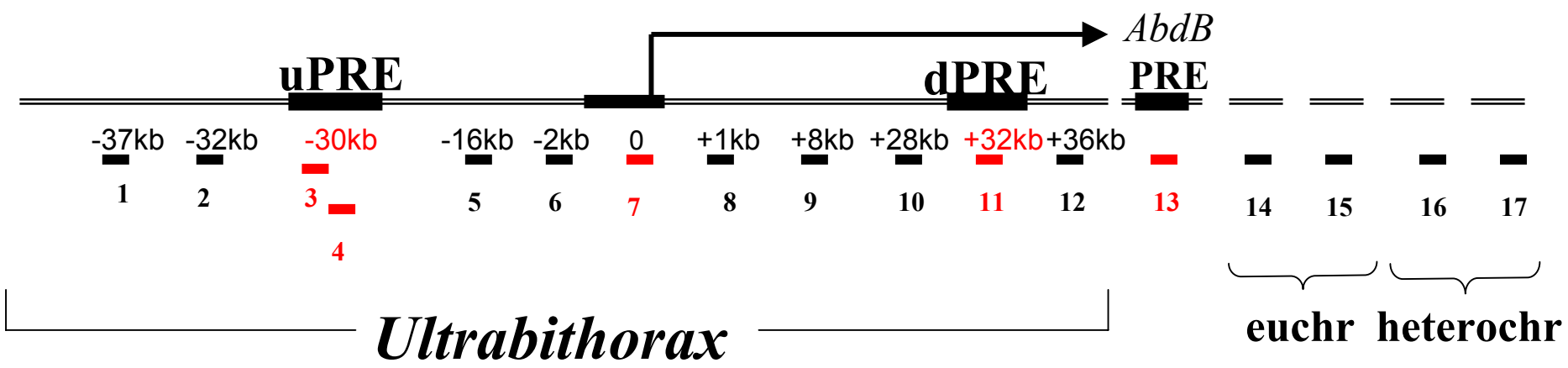
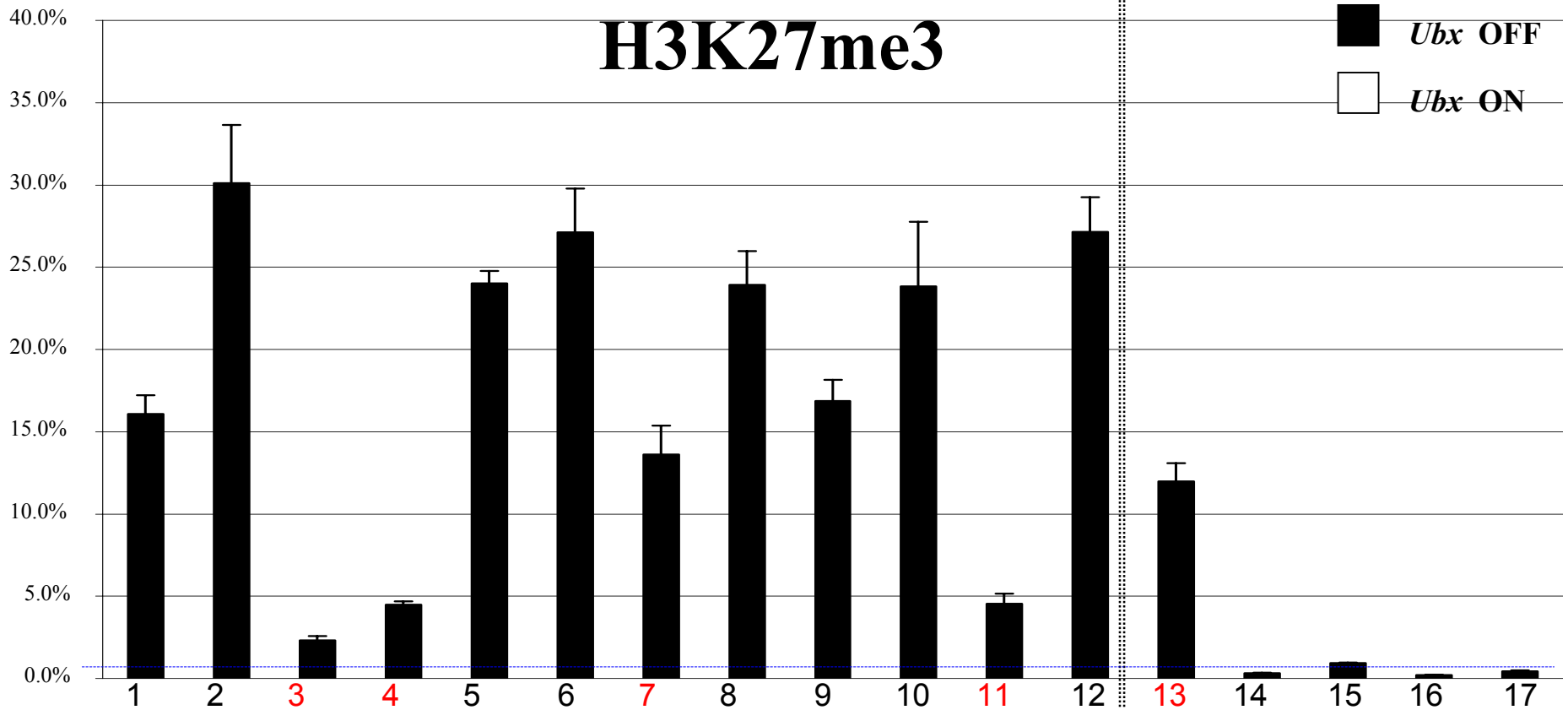

H3K27me3

Ubx OFF
 Ubx ON

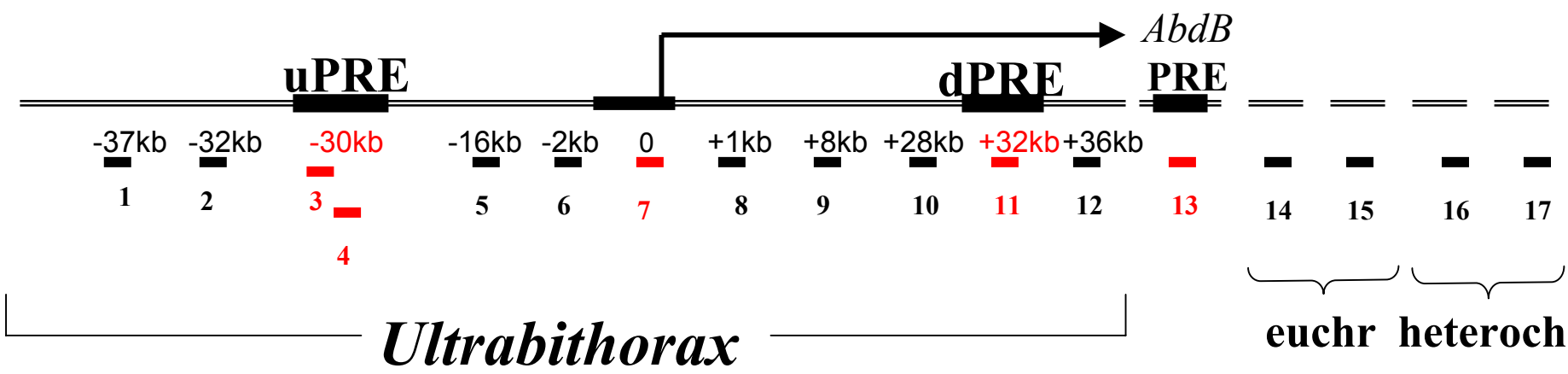
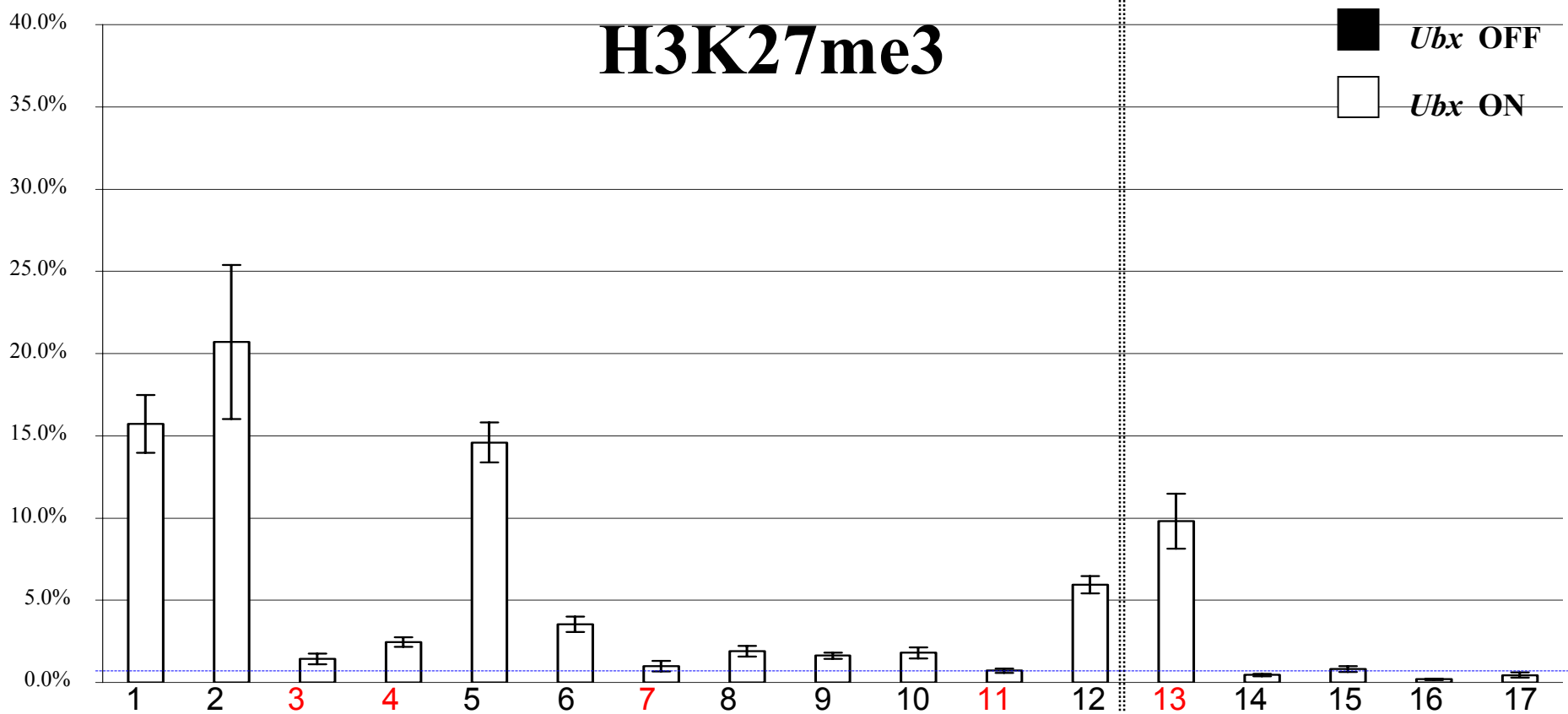

H3K27me3

Ubx OFF
 Ubx ON

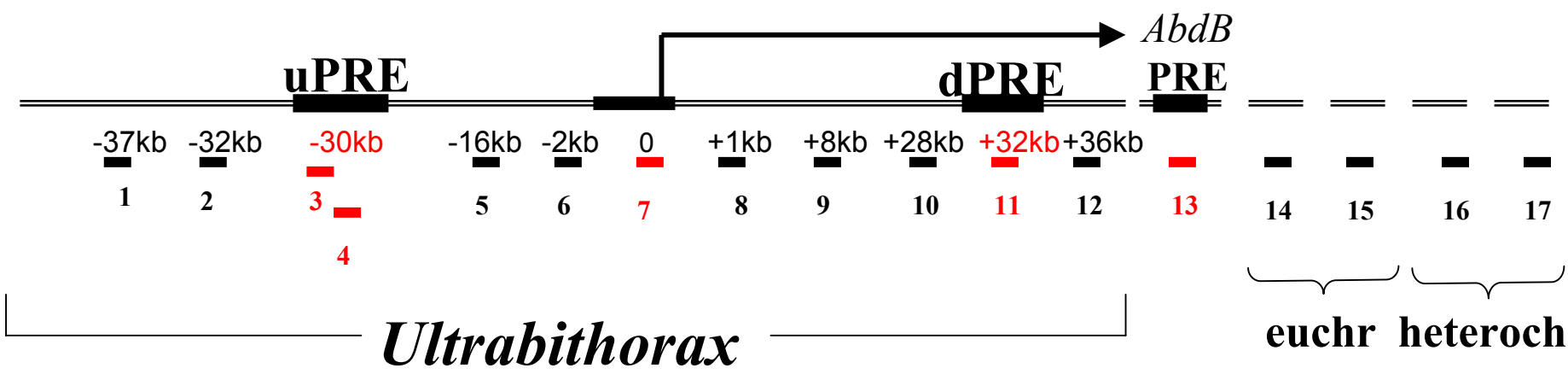
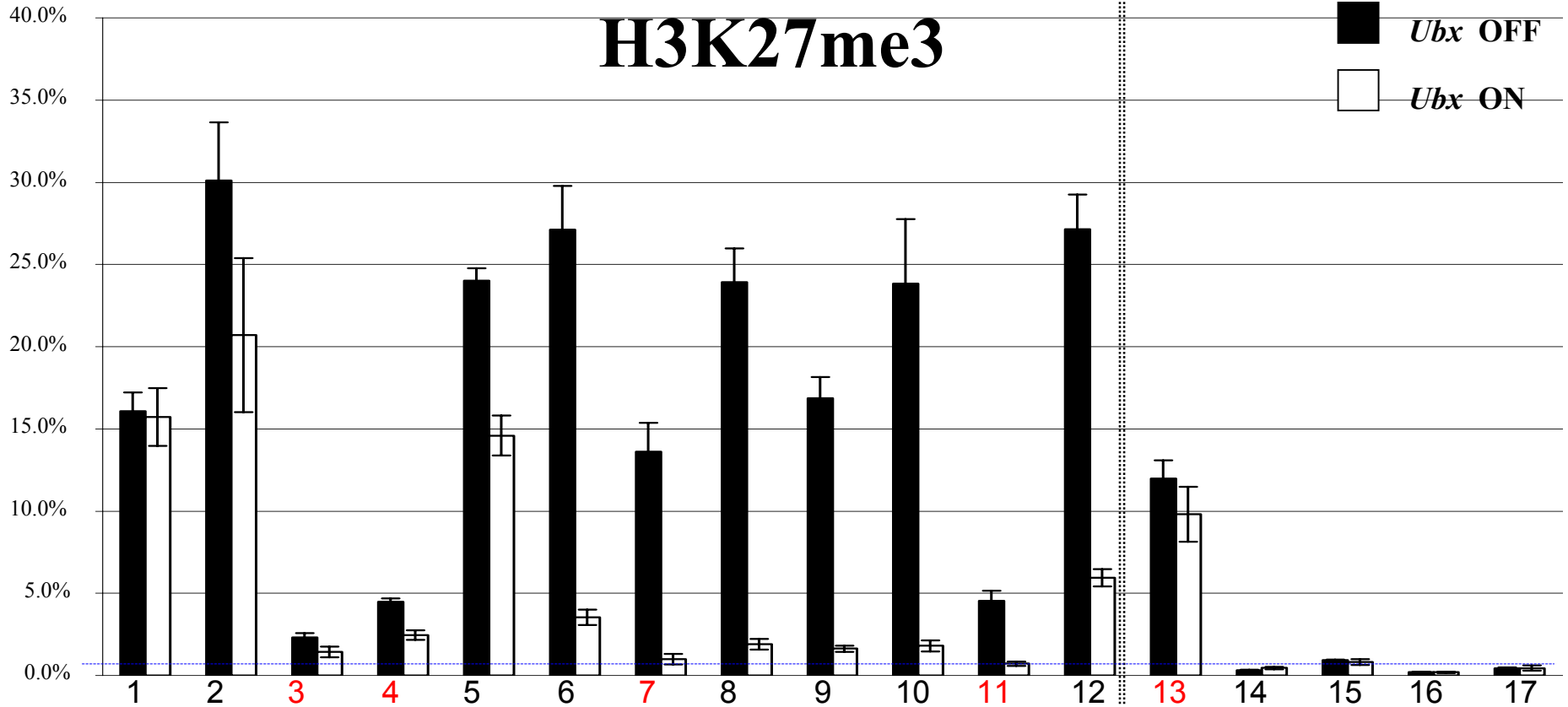

H3K9me3

Ubx OFF
 Ubx ON

* not measured

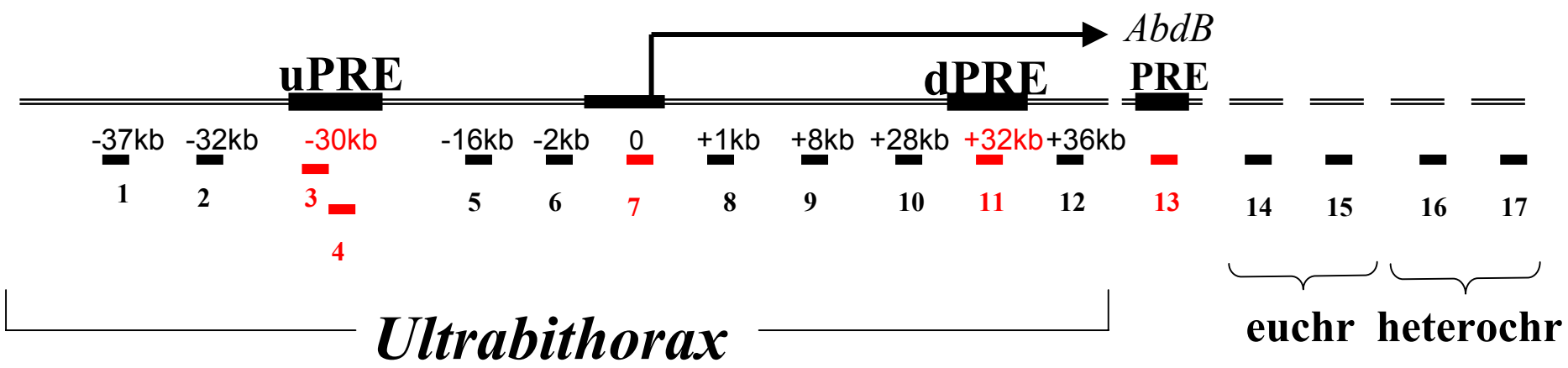
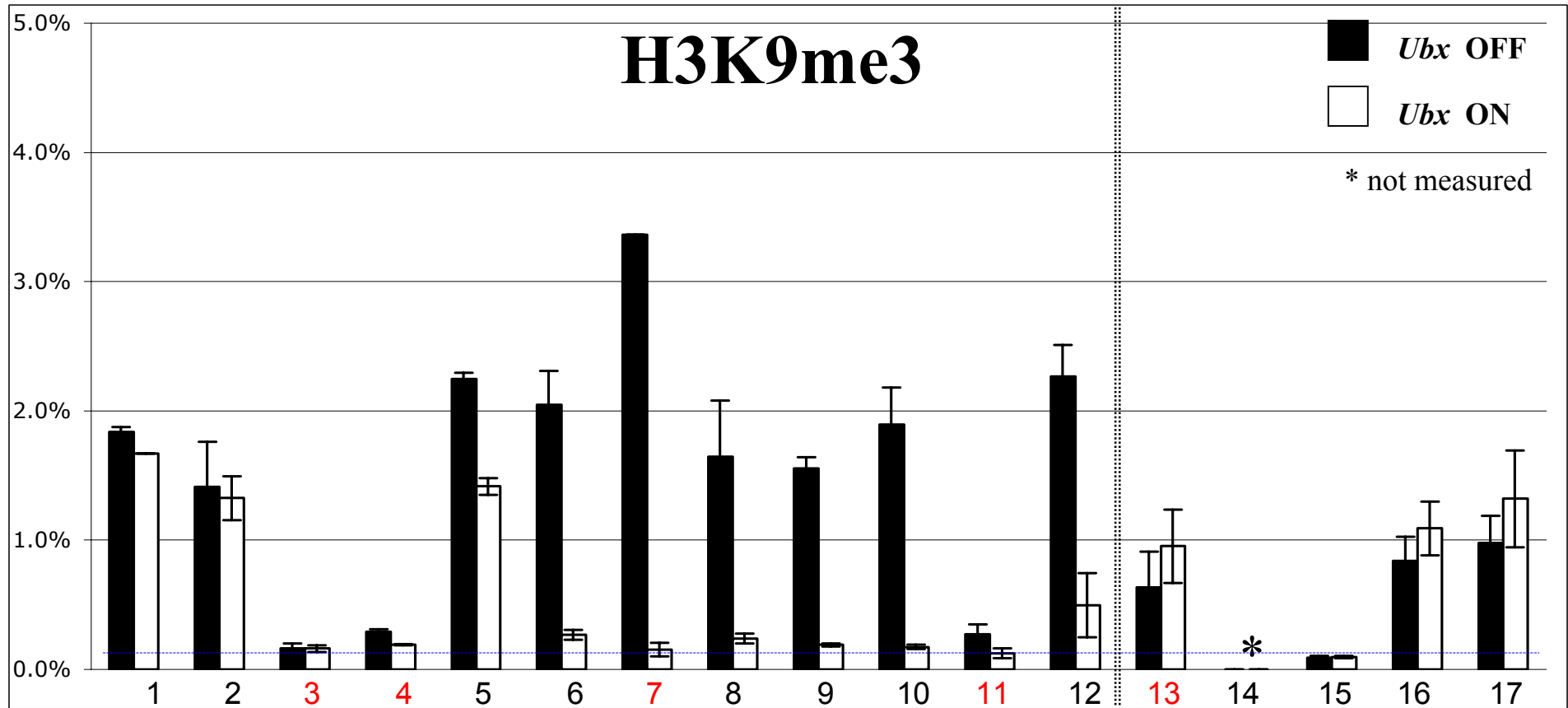

H3K9me2

Ubx OFF
 Ubx ON

* not measured

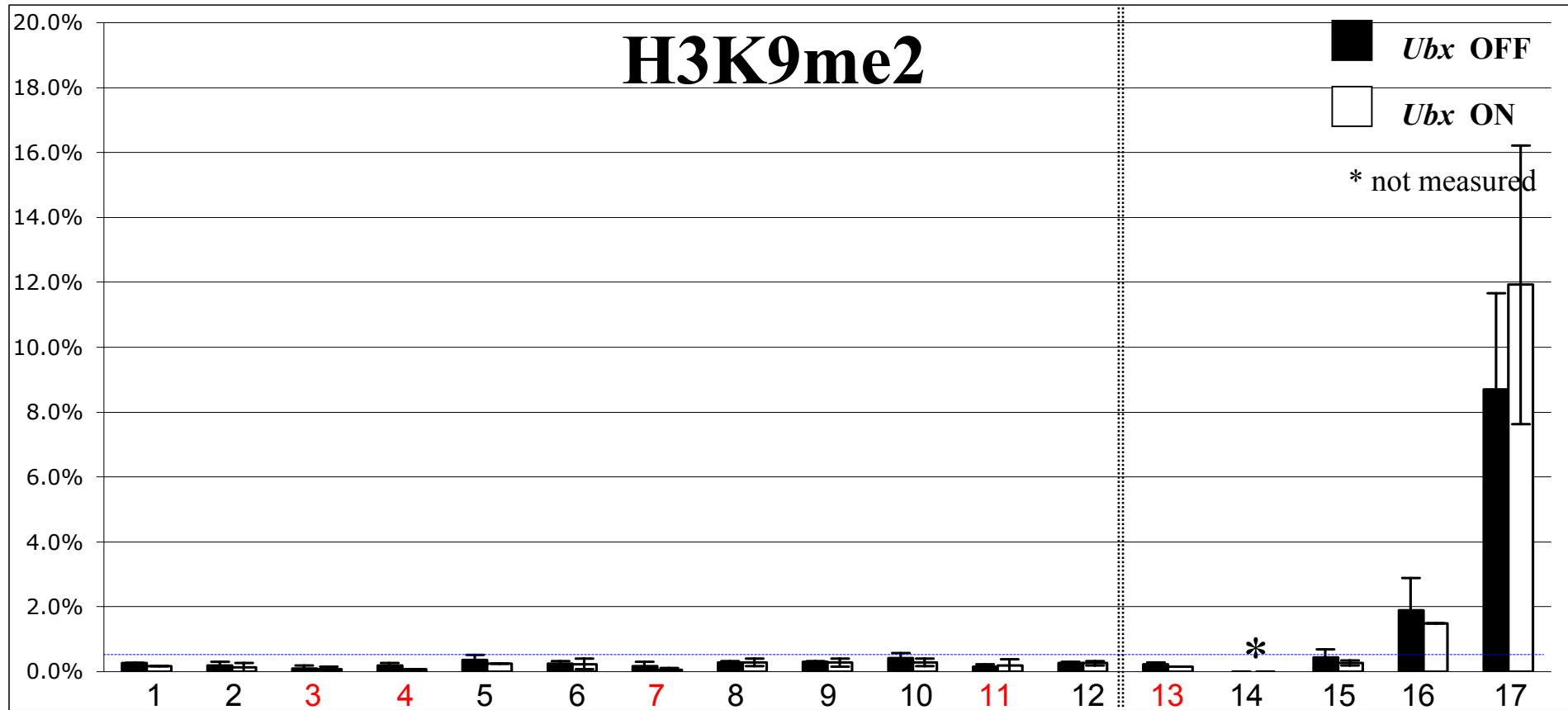

uPRE

dPRE

AbdB

PRE

-37kb -32kb -30kb -16kb -2kb 0 +1kb +8kb +28kb +32kb +36kb

1

2

3

4

5

6

7

8

9

10

11

12

13

14

15

16

17

Ultrabithorax

euchr heterochr

H3K9me3

H3K27me3

OFF

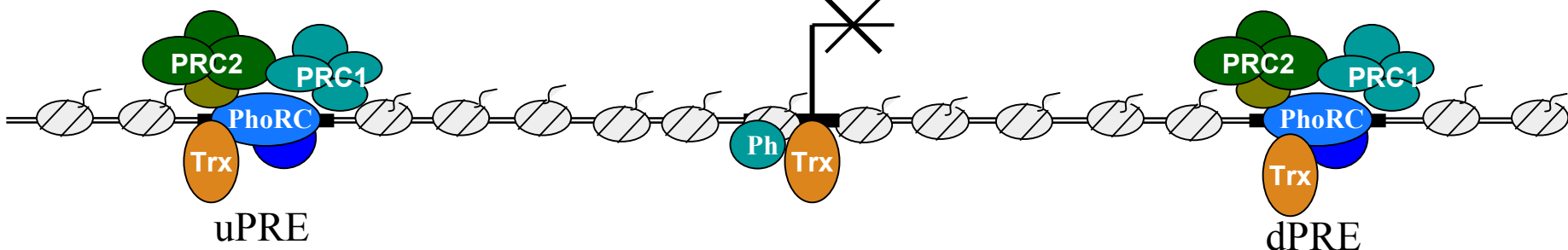

ON

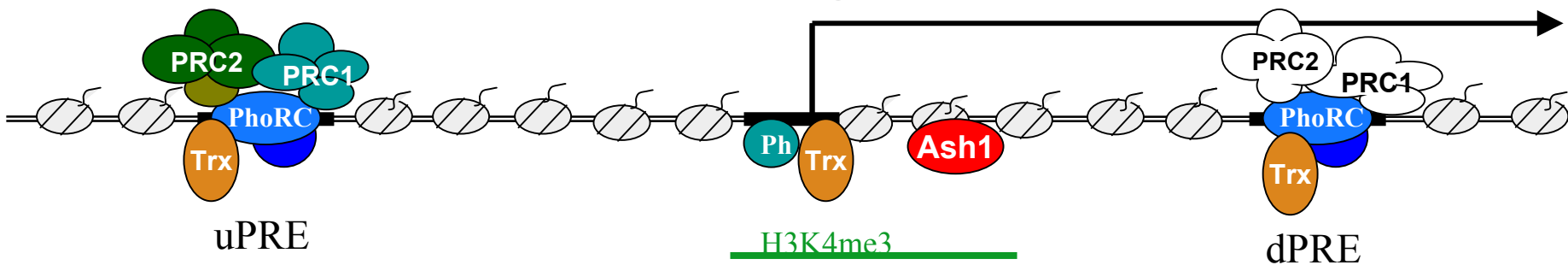

H3K9me3

H3K27me3

Acknowledgements

Jürg Müller

Andres Gaytan de Ayala Alonso

Brigitte Wild

Katarzyna Oktaba Sosin

Maxim Nekrasov

Tetyana Klimenko

Vladimir Benes

Ubx

